

High Performance Force Control for Shape Memory Alloy (SMA) Actuators

Roy Featherstone

(reporting the work of Yee Harn Teh)

Dept. Information Engineering,
The Australian National University

<http://users.rsise.anu.edu.au/~roy/SMA>

The Shape Memory Effect

An alloy exhibiting the *shape memory effect* has the following property:

it can be deformed easily when cold, but returns to its original shape when heated.

The shape recovery process is accompanied by large forces, which can be harnessed to perform mechanical work.

The Shape Memory Effect

The effect is caused by a transformation between two crystal phases:

1. an *austenite* crystal phase, which is stable at higher temperatures, and
2. a *martensite* crystal phase, which is stable at lower temperatures.

Austenite crystals are cubic: 

Martensite crystals are monoclinic:  or 

The Shape Memory Effect

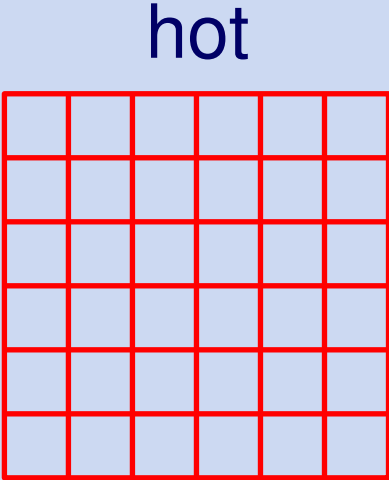

cooling

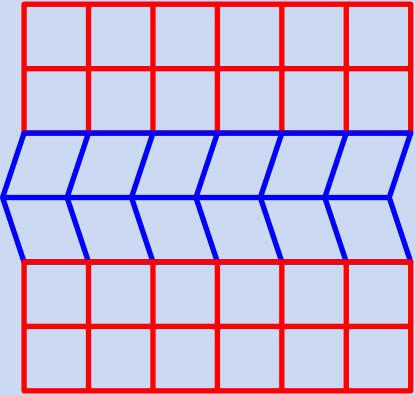

cold

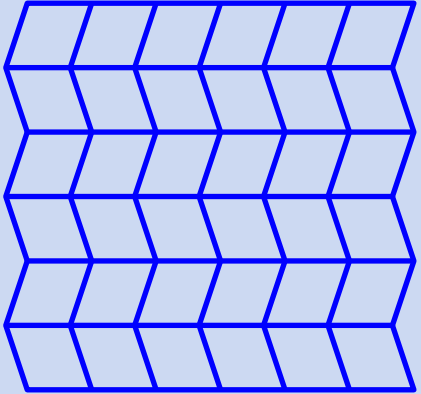

deform

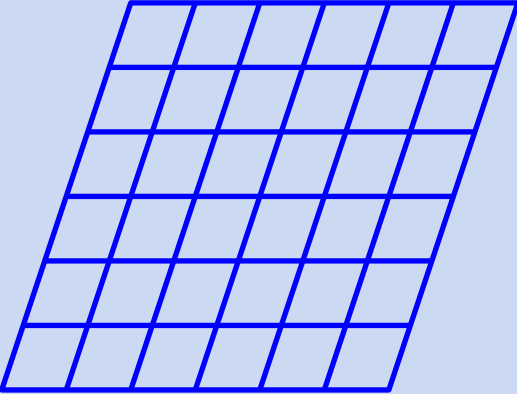

warming

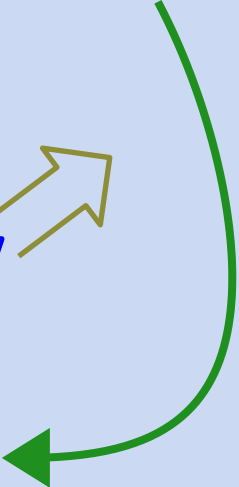
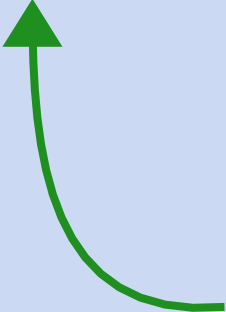
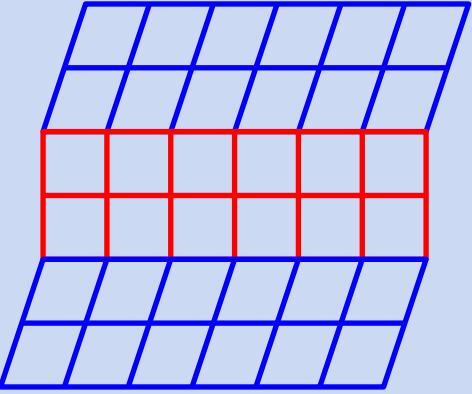

The Shape Memory Effect

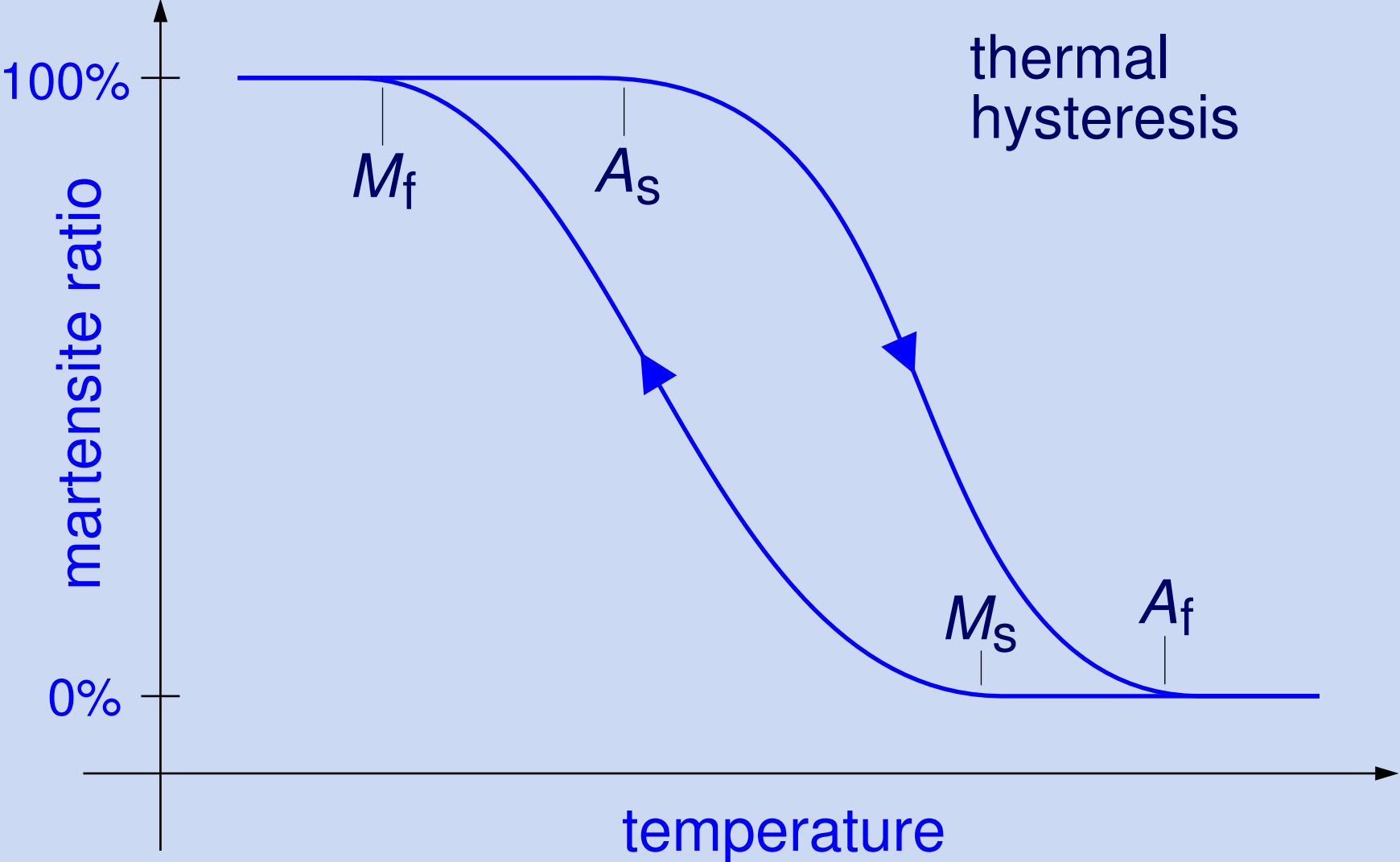

SMA Actuators

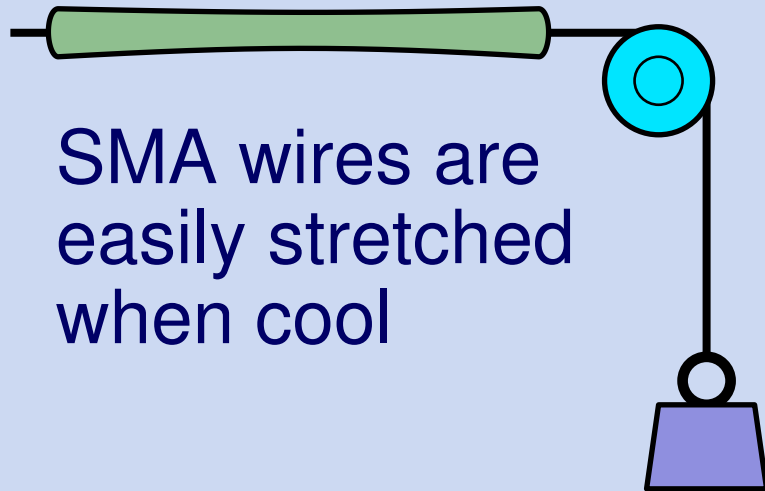

SMA wires are easily stretched when cool

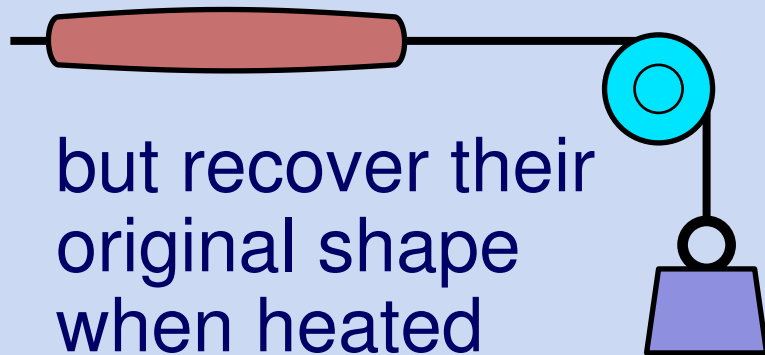

but recover their original shape when heated

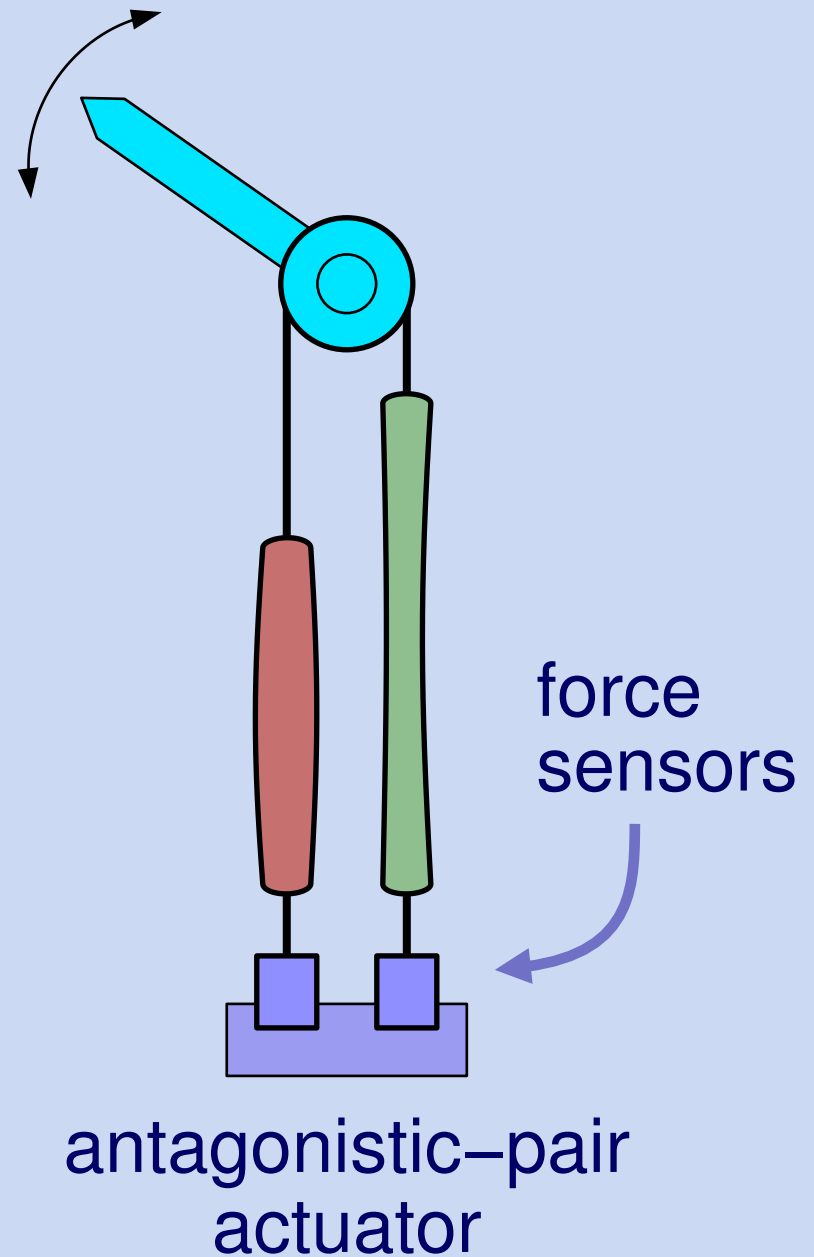

SMA Actuators

Advantages

- mechanically simple
- large force outputs
- high force-to-weight ratio
- cheap
- clean
- silent
- spark-free
- easily miniaturized

Disadvantages

- inefficient
- low strain
- slow
- hard to control accurately

a better control system can fix these

Force Control System

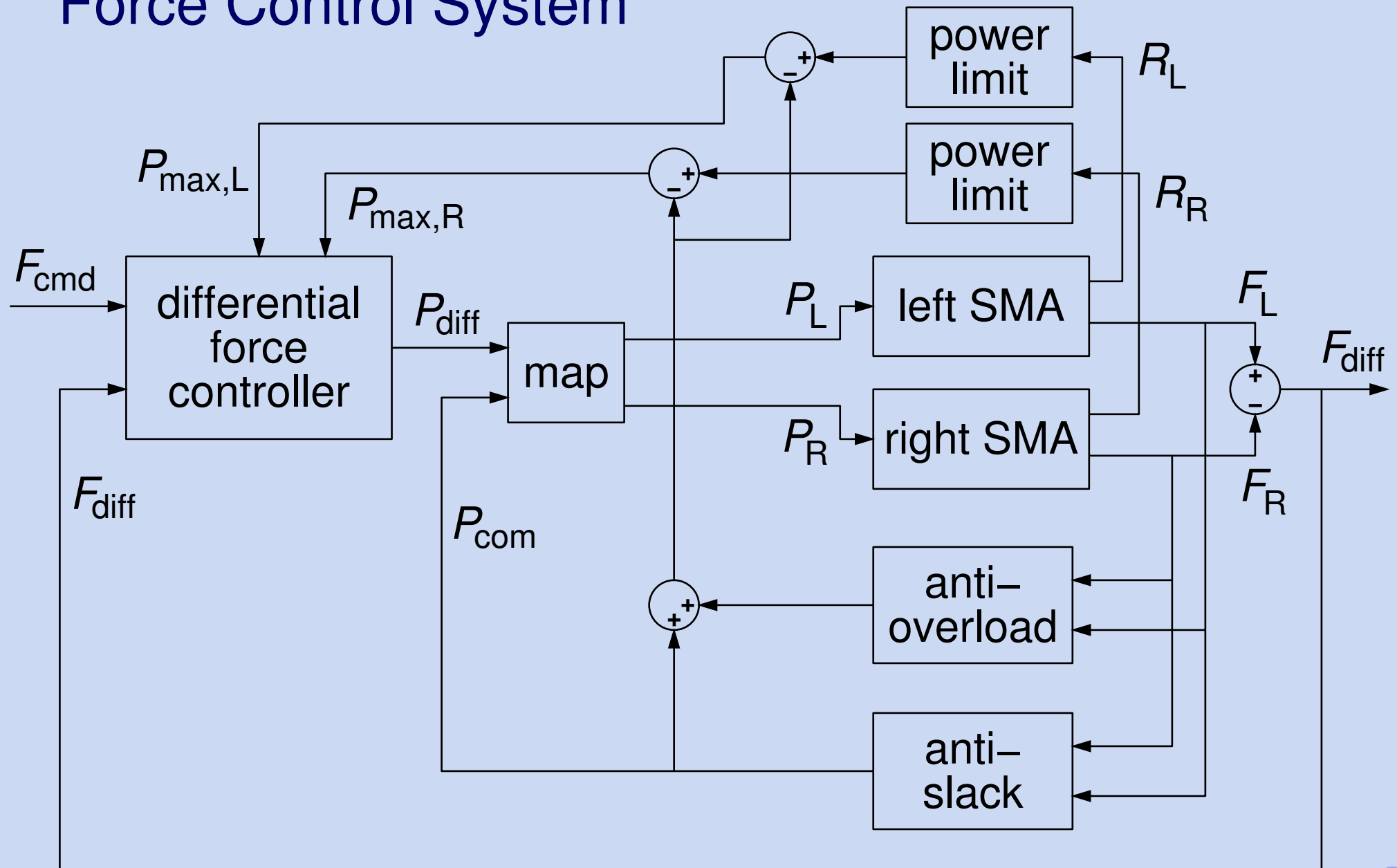

Force Control System

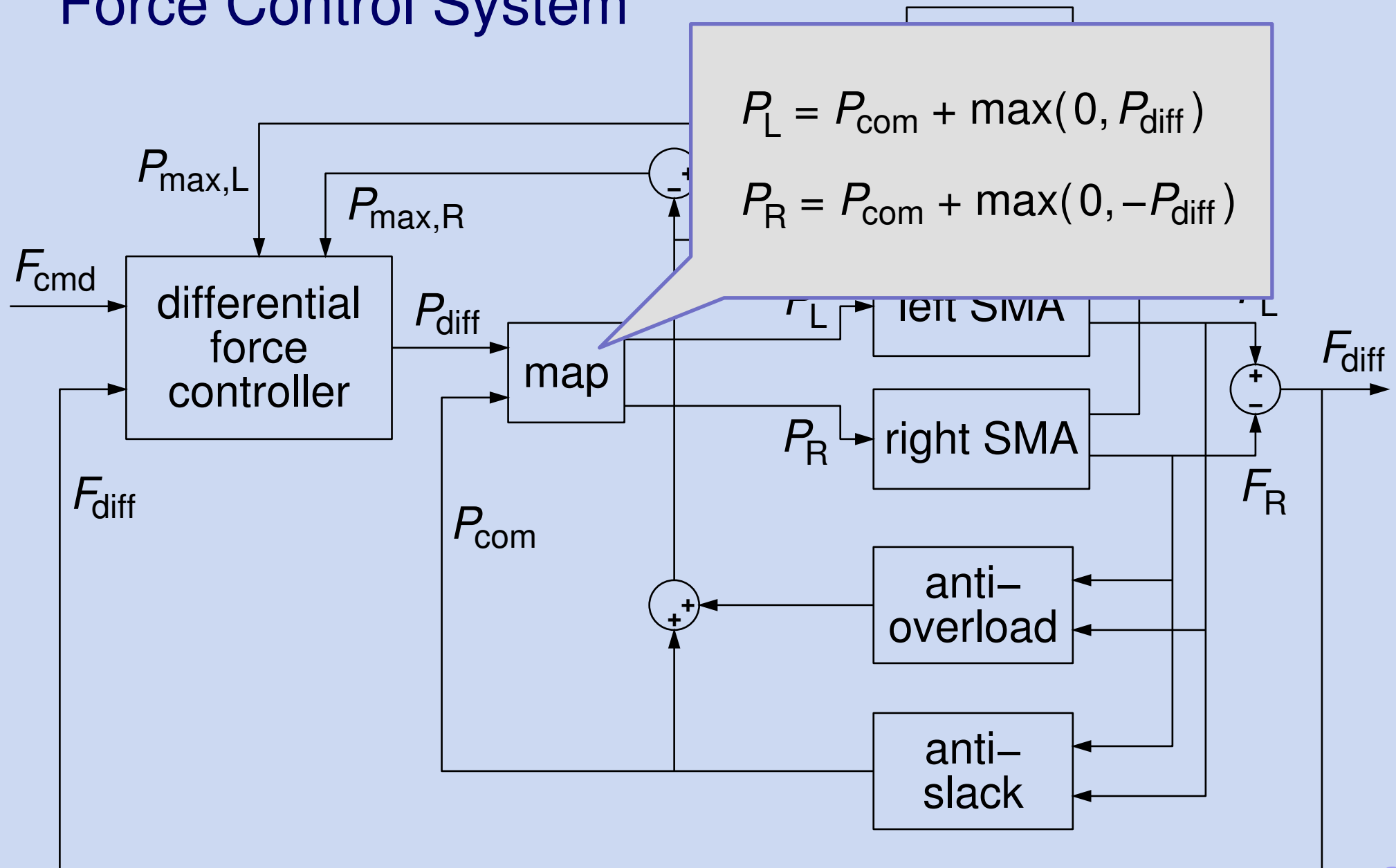

Differential Controller

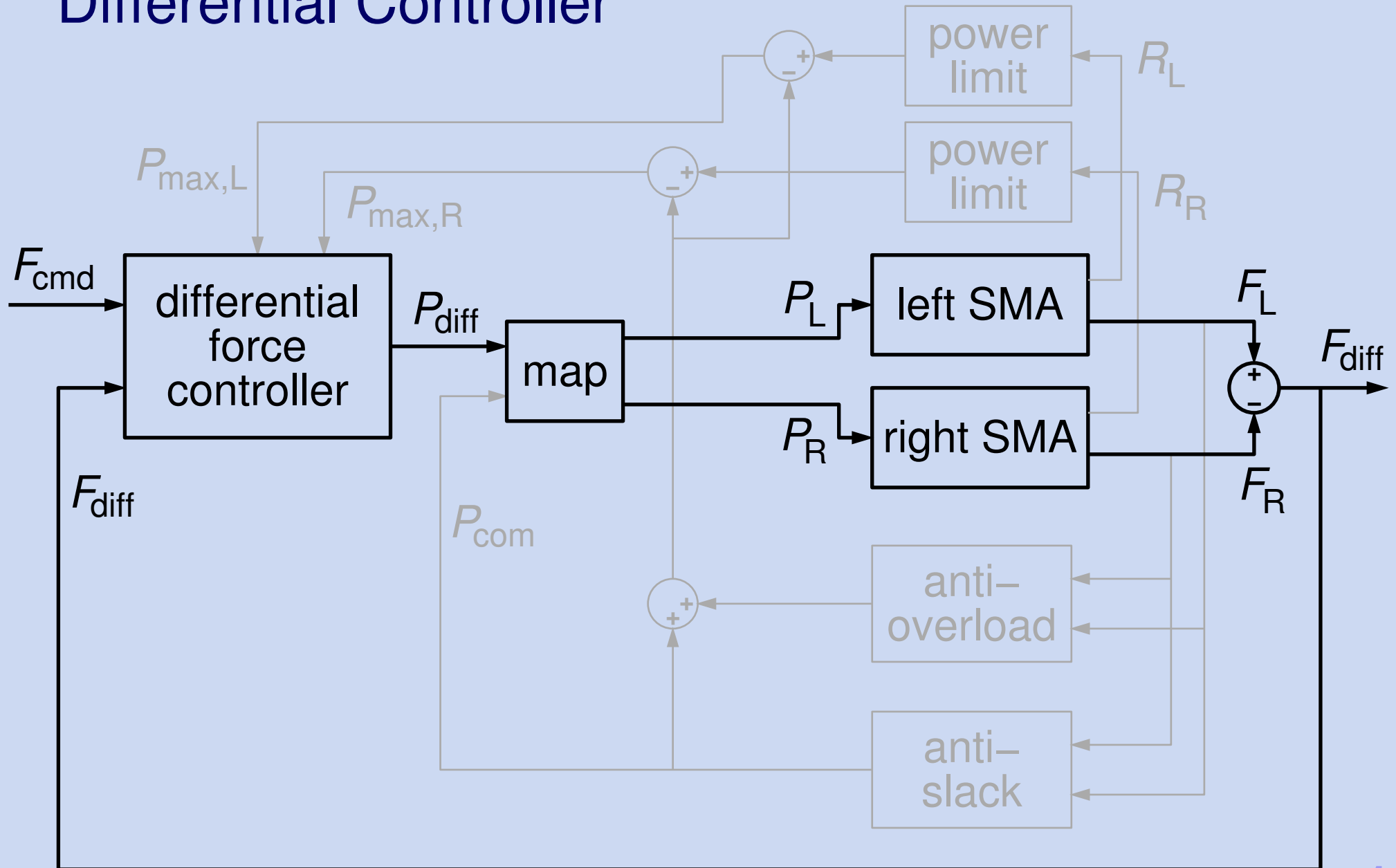

Differential Controller

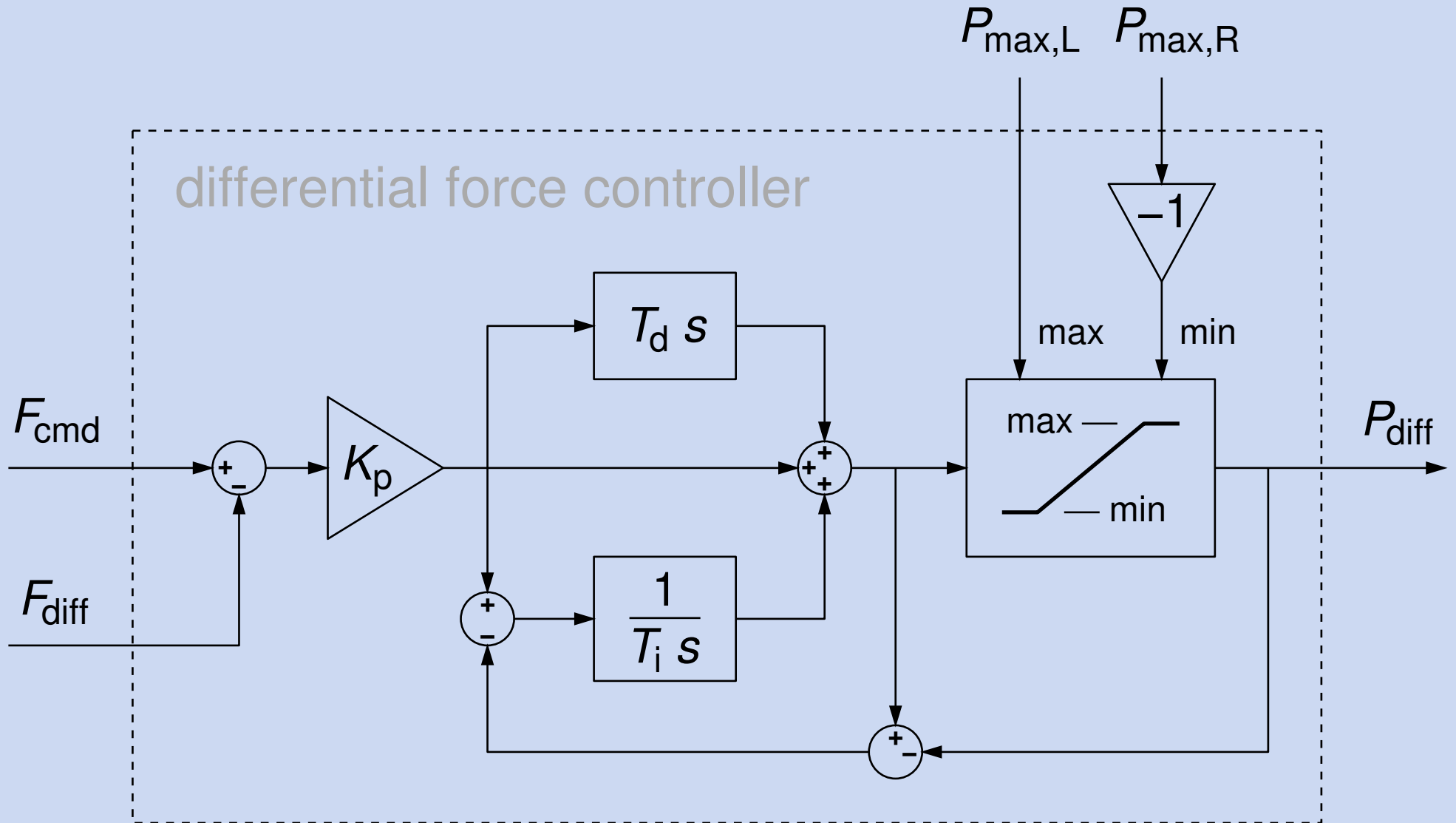

Behaviour of the Plant

The *small-signal AC response* of nickel–titanium SMA approximates to a first–order low–pass filter.

- Gain varies with mean stress and strain in a 7–8 dB range
- Phase is *independent of stress and strain*
- Cut–off frequency varies with wire diameter

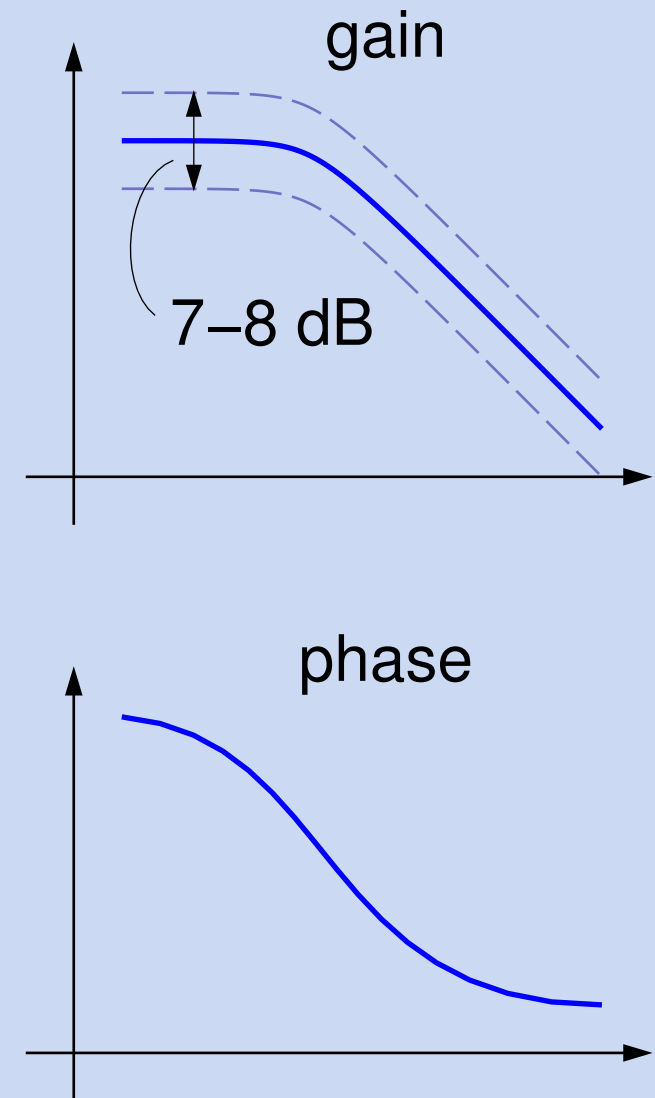

What Happened to the Hysteresis?

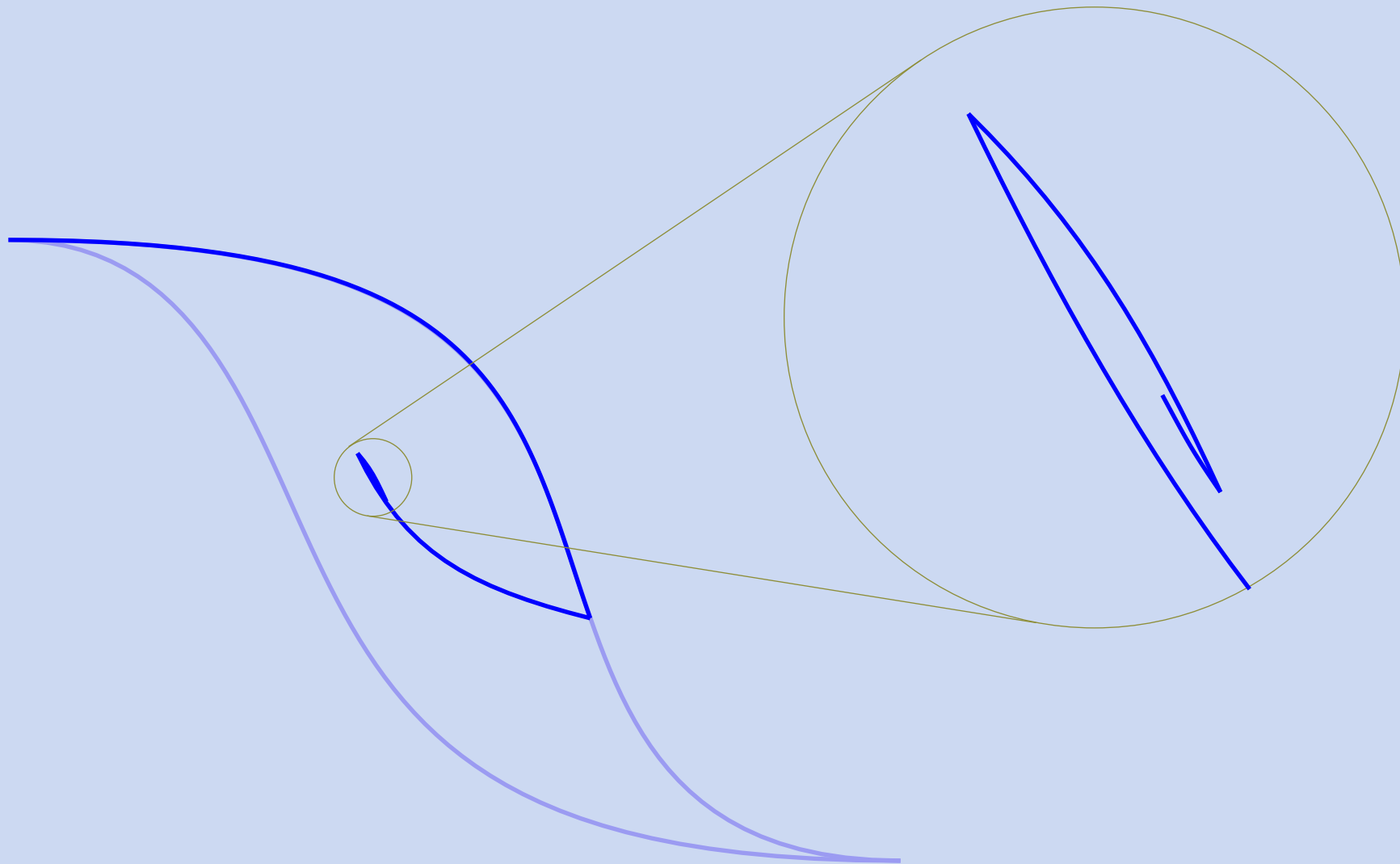

A Problem

When Flexinol™ wires are used in an antagonistic–pair actuator, they quickly develop a *two–way shape memory effect*, in which the wires *actively lengthen* as they cool, even if the tension on the wire is zero.

Symptom: The wires can become slack as they cool.

Remedy: An *anti–slack mechanism* that maintains a minimum tension on both wires at all times.

Anti-Slack Mechanism

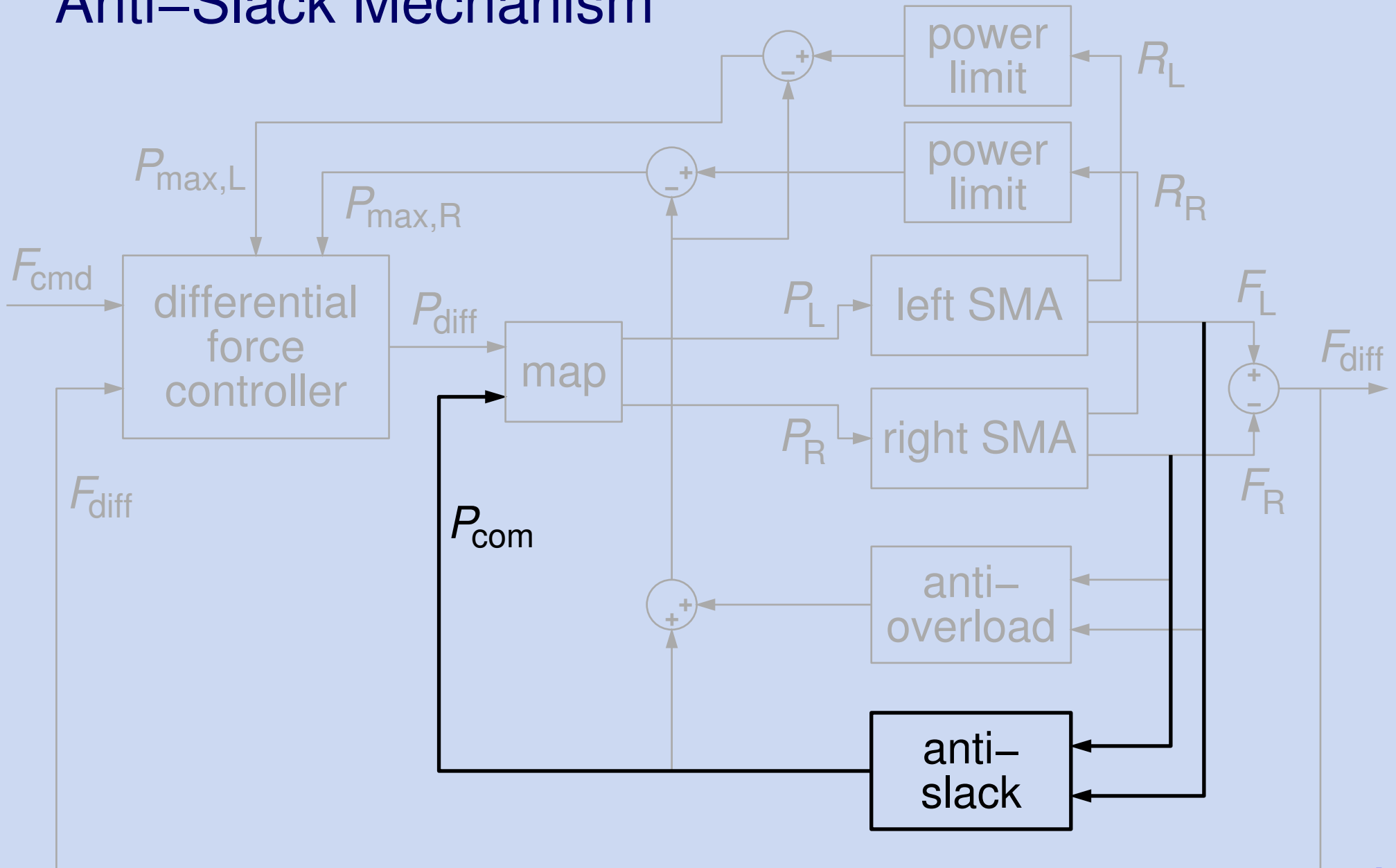

Anti-Slack Mechanism

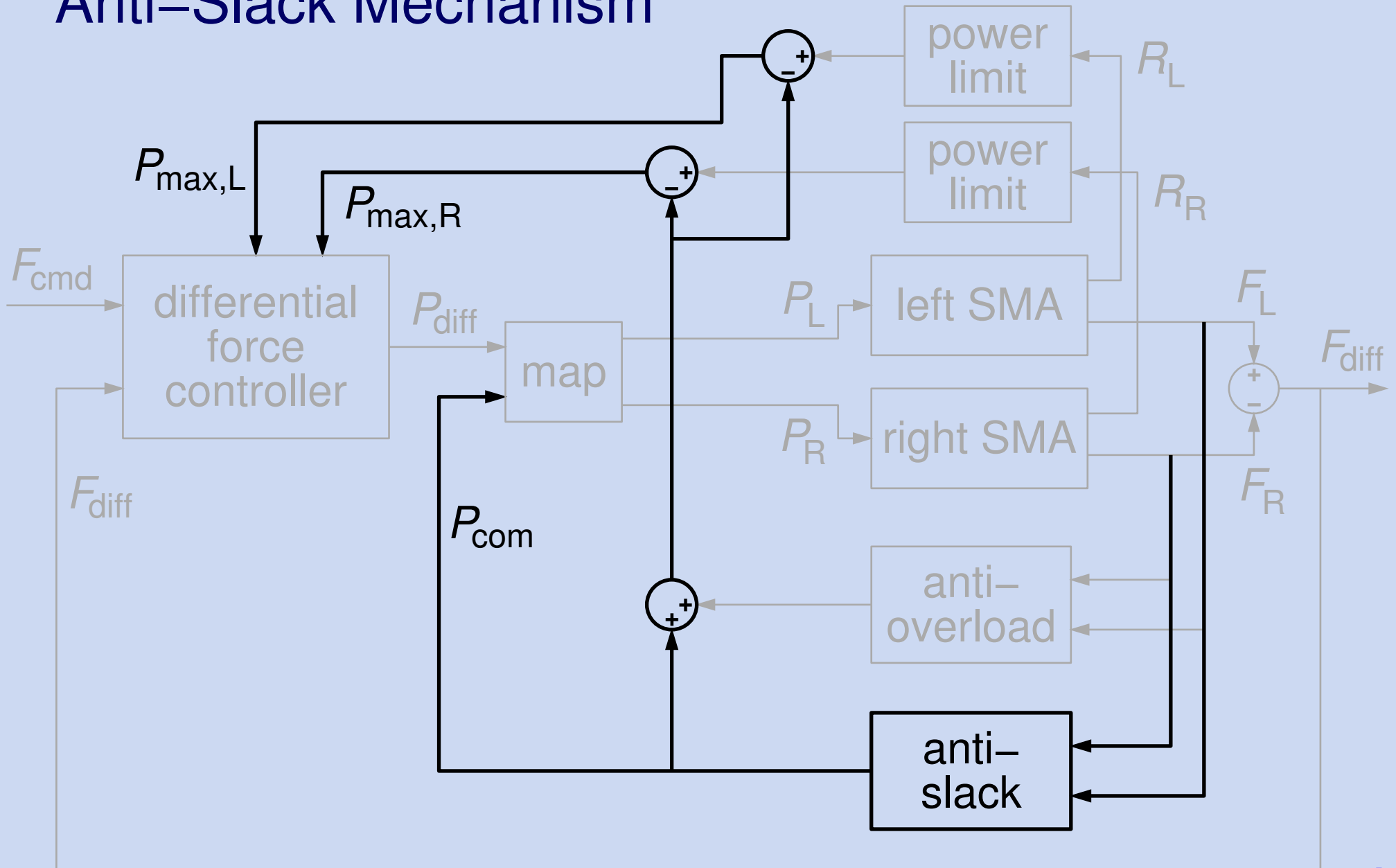

Anti-Slack Mechanism

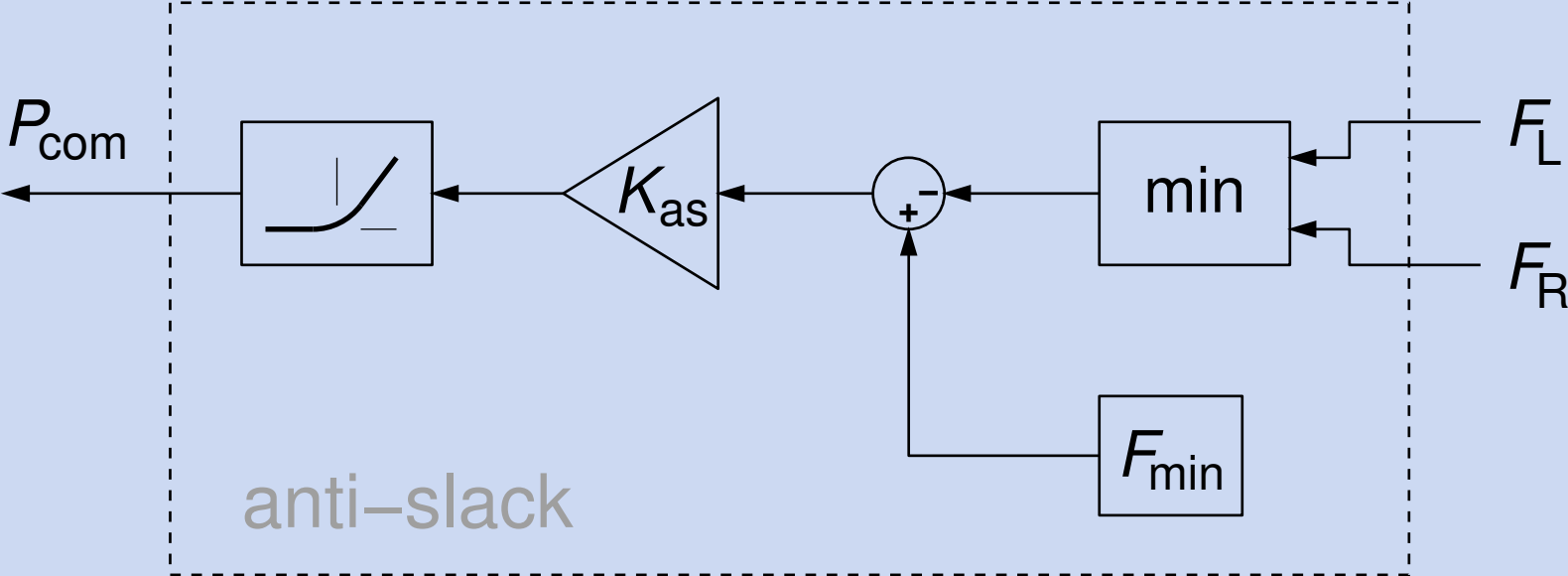

Anti-Slack Mechanism

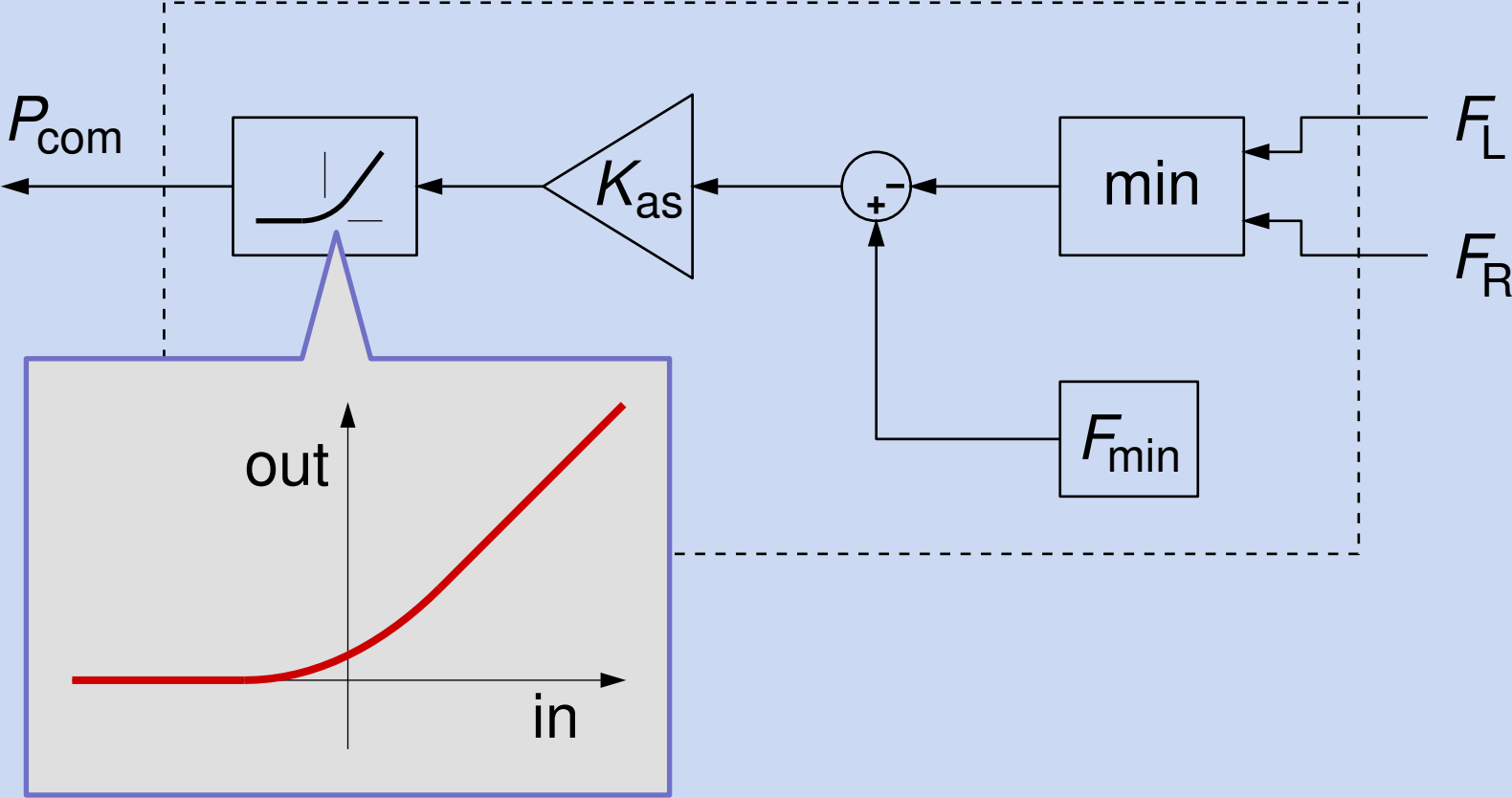

without anti-slack

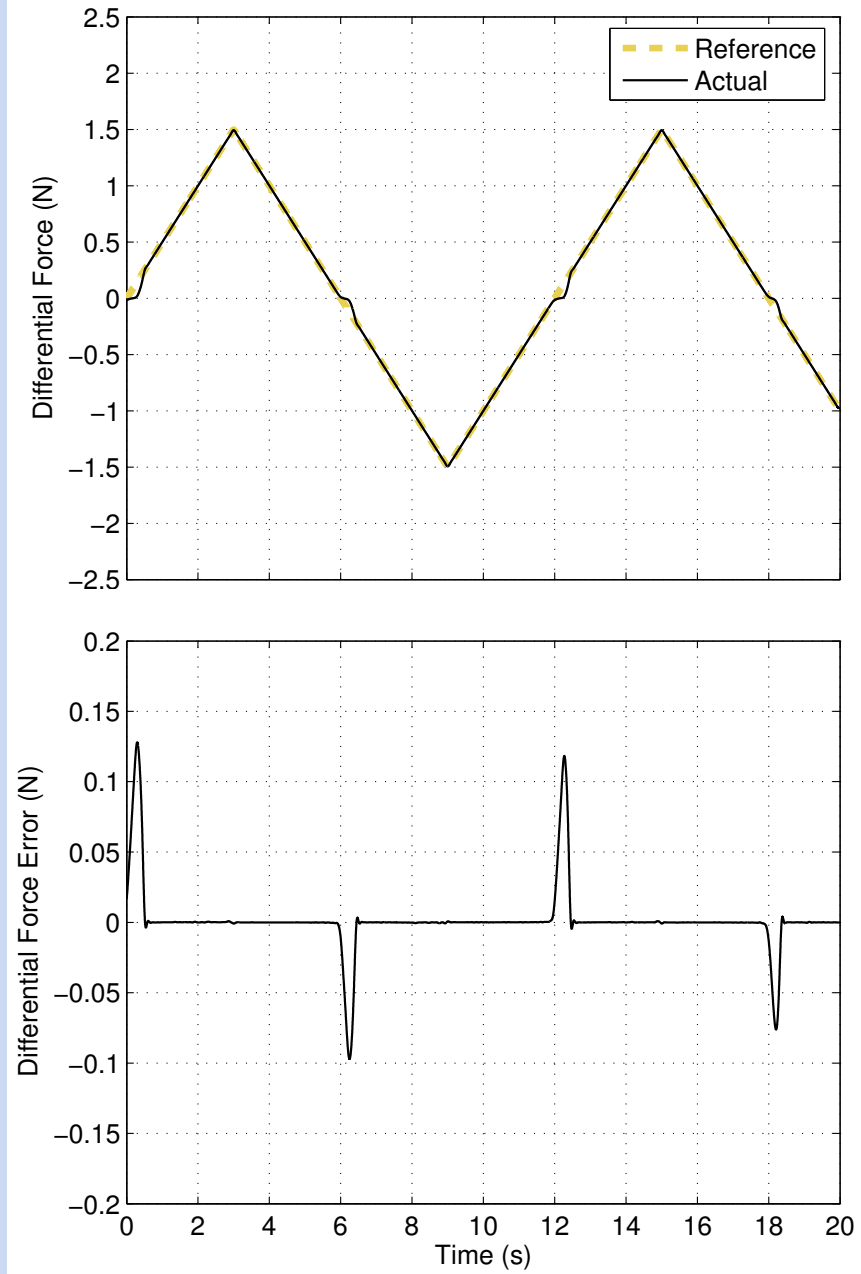

with anti-slack

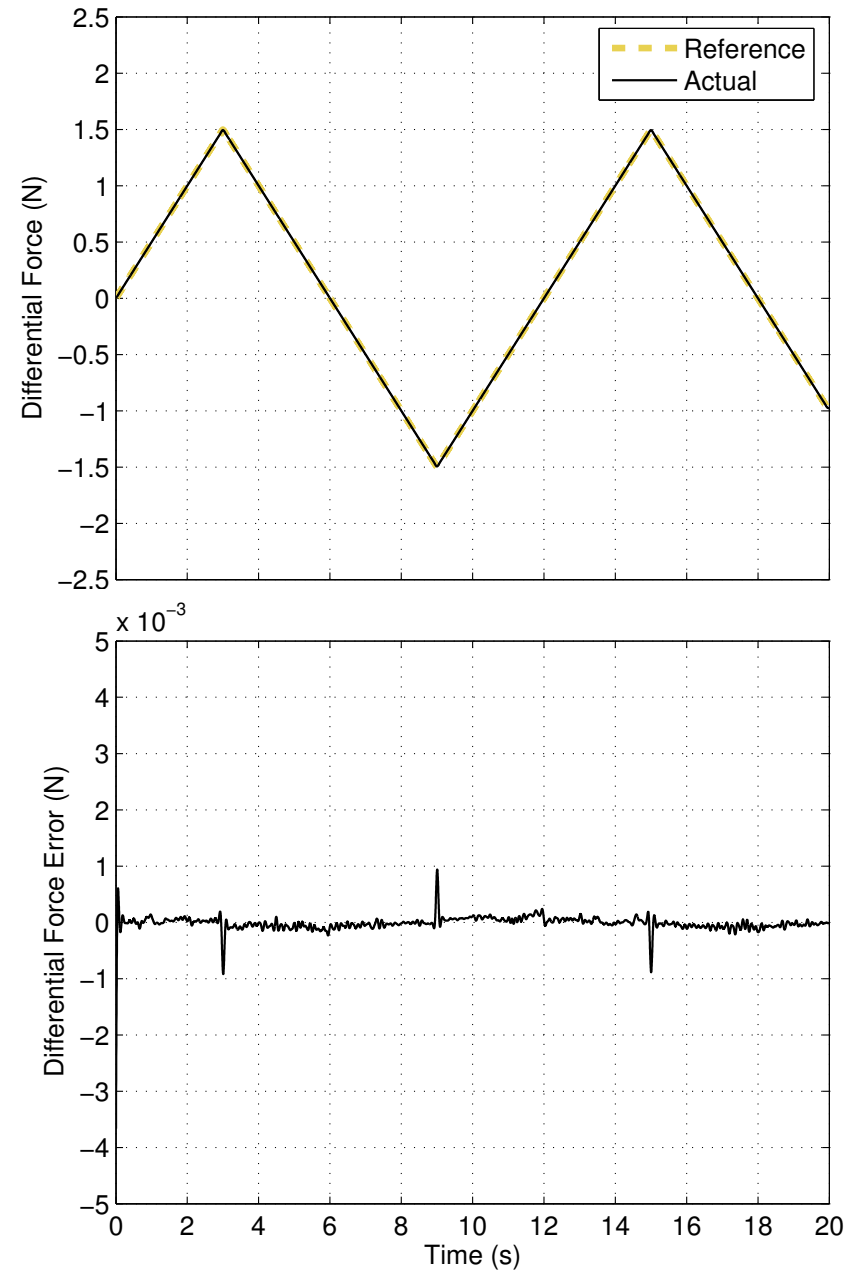

Another Problem

We want the actuator to be as fast as possible. The speed can be increased by means of

- a faster heating rate, and/or
- a faster cooling rate.

A faster heating rate is more beneficial and easier to implement.

problem: how to achieve faster heating without risk of overheating?

Why Focus on Heating?

Excerpt from Flexinol™ data sheet:

Diameter (mm)	Current (mA)	Contraction Time (sec)	Off Time 70C	Off Time 90C
0.050	50	1	0.3	0.1
0.075	100	1	0.5	0.2
0.100	180	1	0.8	0.4

If we use the recommended safe heating currents then, for a thin wire, heating takes longer than cooling.

Rapid Electrical Heating

To obtain a rapid response from an SMA wire, we need a heating strategy that

- allows *large heating powers* when there is *no risk* of overheating, but
- allows only a *safe heating power* when there *is a risk* of overheating.

This can be accomplished by

- *measuring the electrical resistance* of the wire, and
- calculating a *heating power limit* as a function of the measured resistance

Electrical Resistance vs. Temperature

The electrical resistance (of nitinol) varies with the martensite ratio, and therefore also with temperature, because the resistivity of the martensite phase is about 20% higher than the resistivity of the austenite phase.

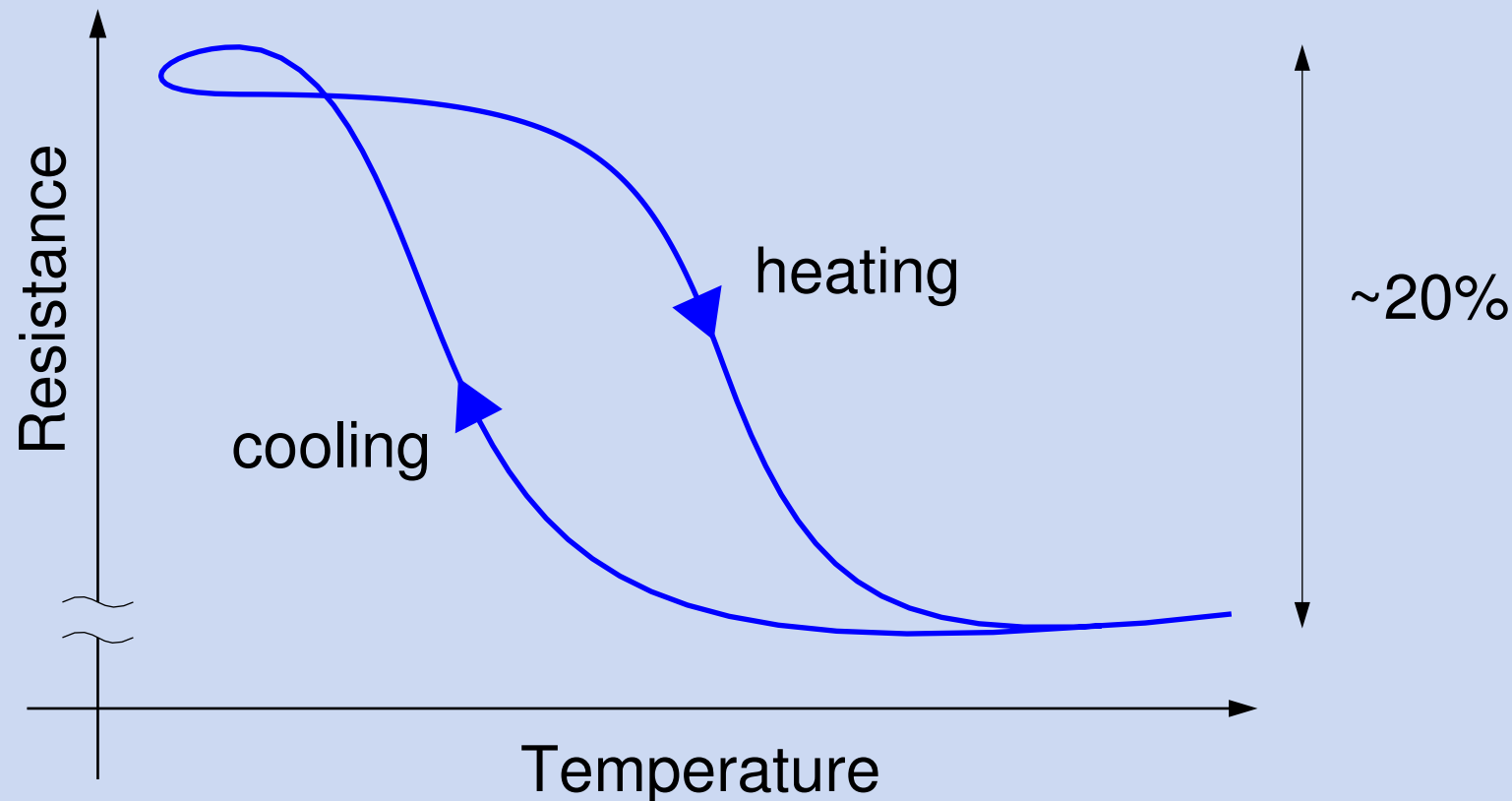

Calculating the Power Limit

1. Choose a threshold resistance, R_{th} , which is equal to the hot resistance of the wire plus a safety margin.

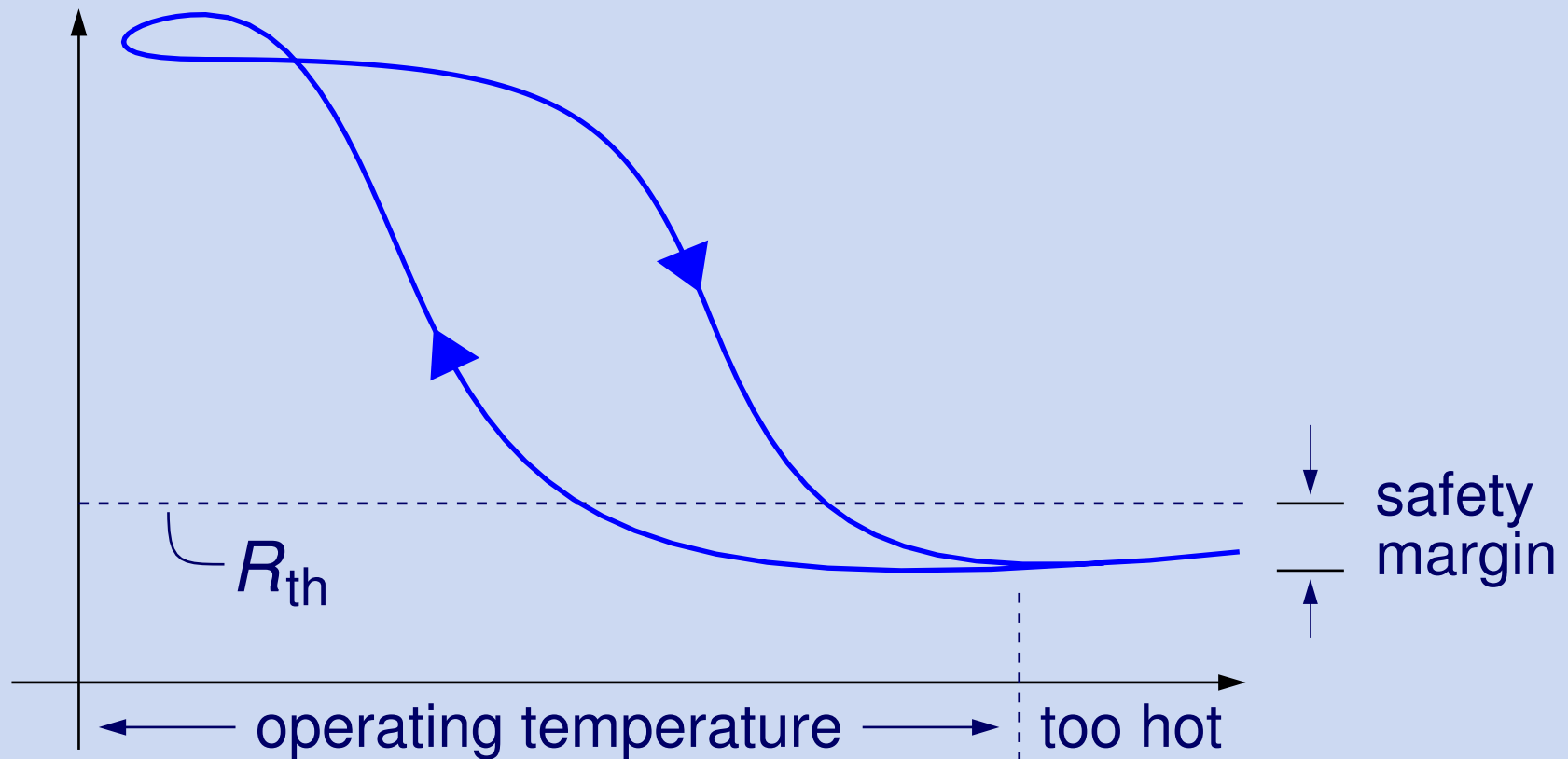

Calculating the Power Limit

2. Calculate the power limit, P_{\max} , as a function of the measured resistance, R_{meas} .

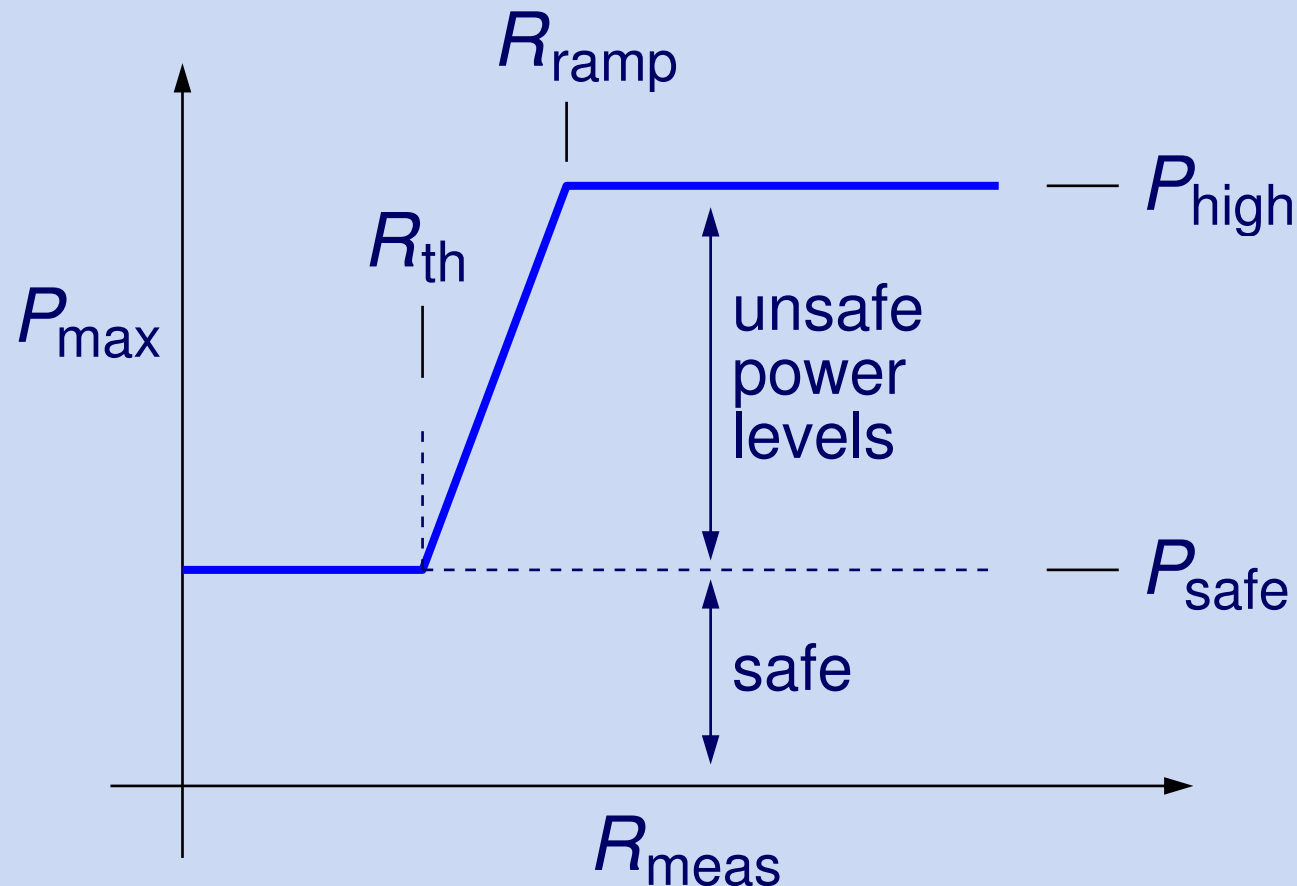

Rapid Heating Mechanism

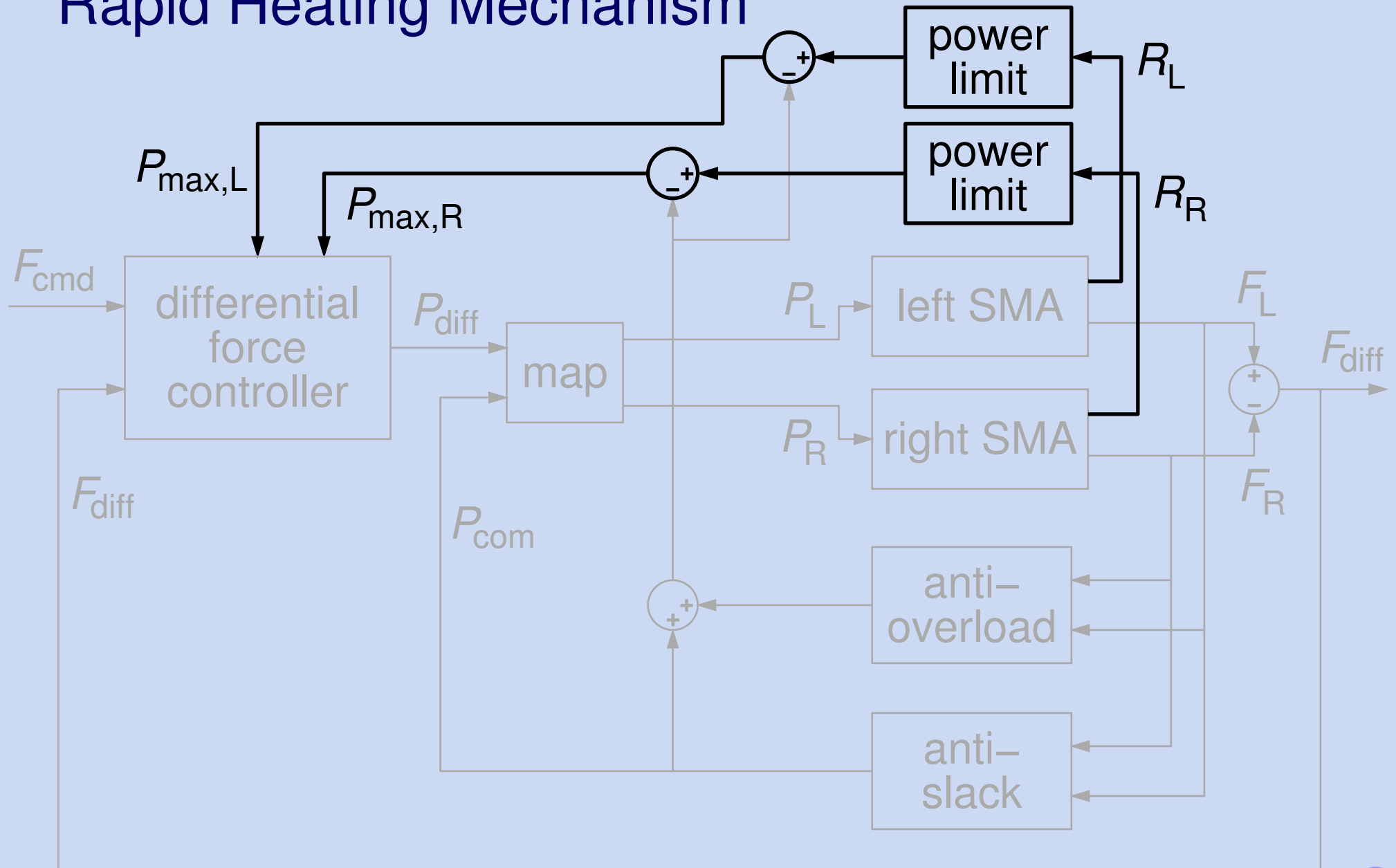

without rapid heating

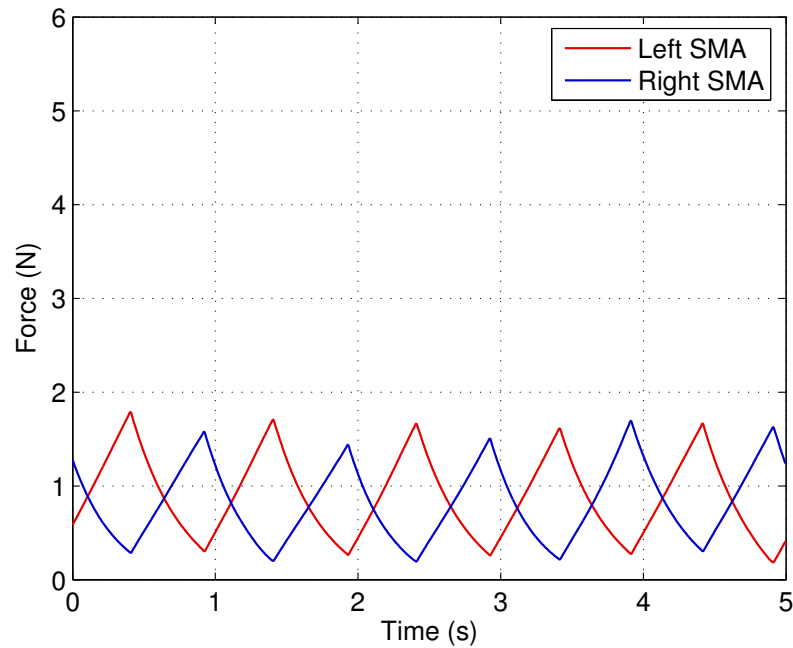
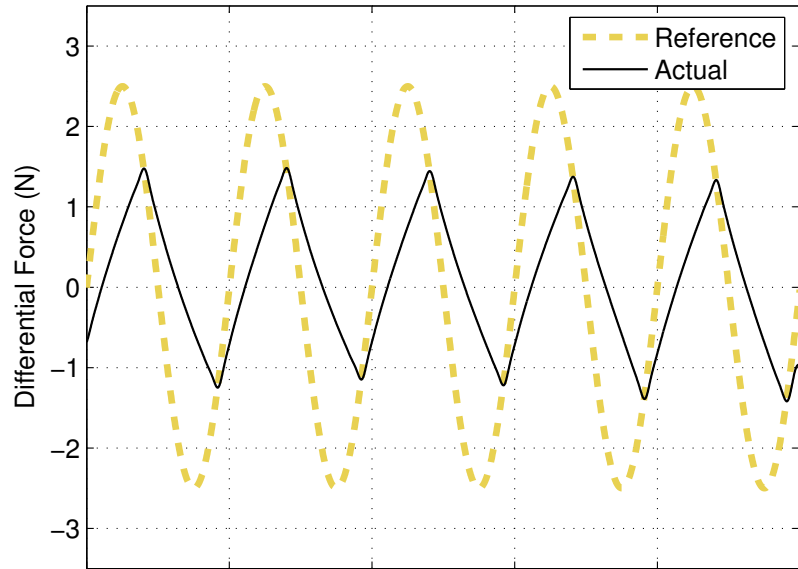

with rapid heating

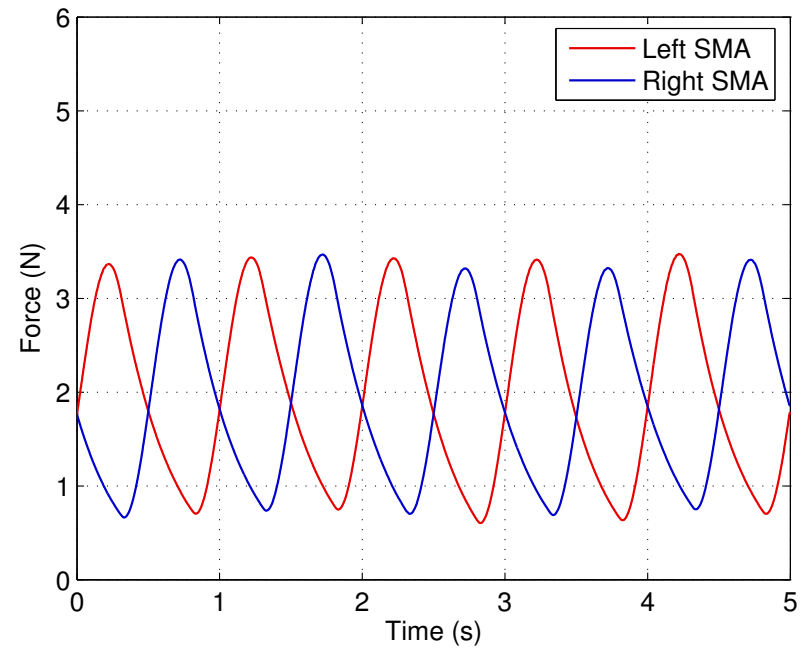
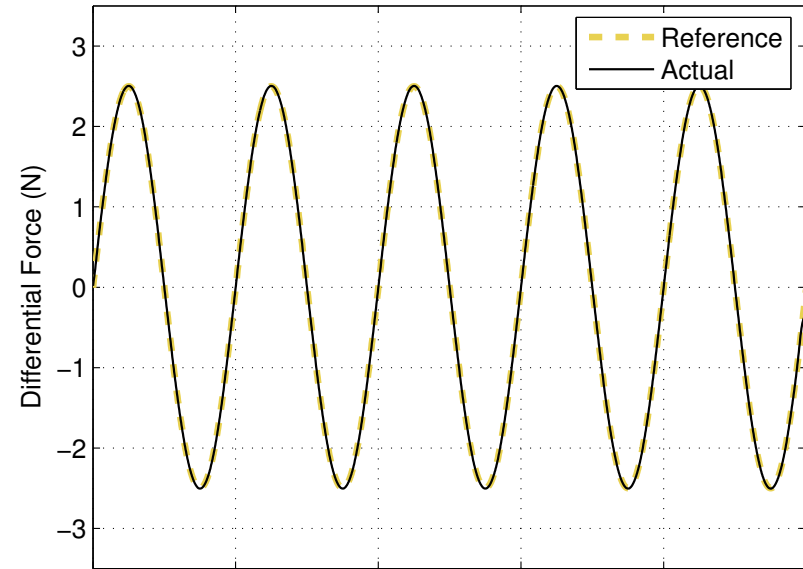

Yet Another Problem

Rapid heating can produce excessively high tensions on the wires, which can cause damage.

remedy: an *anti-overload mechanism* that *cuts the heating power* if the tension goes too high.

Anti-Overload Mechanism

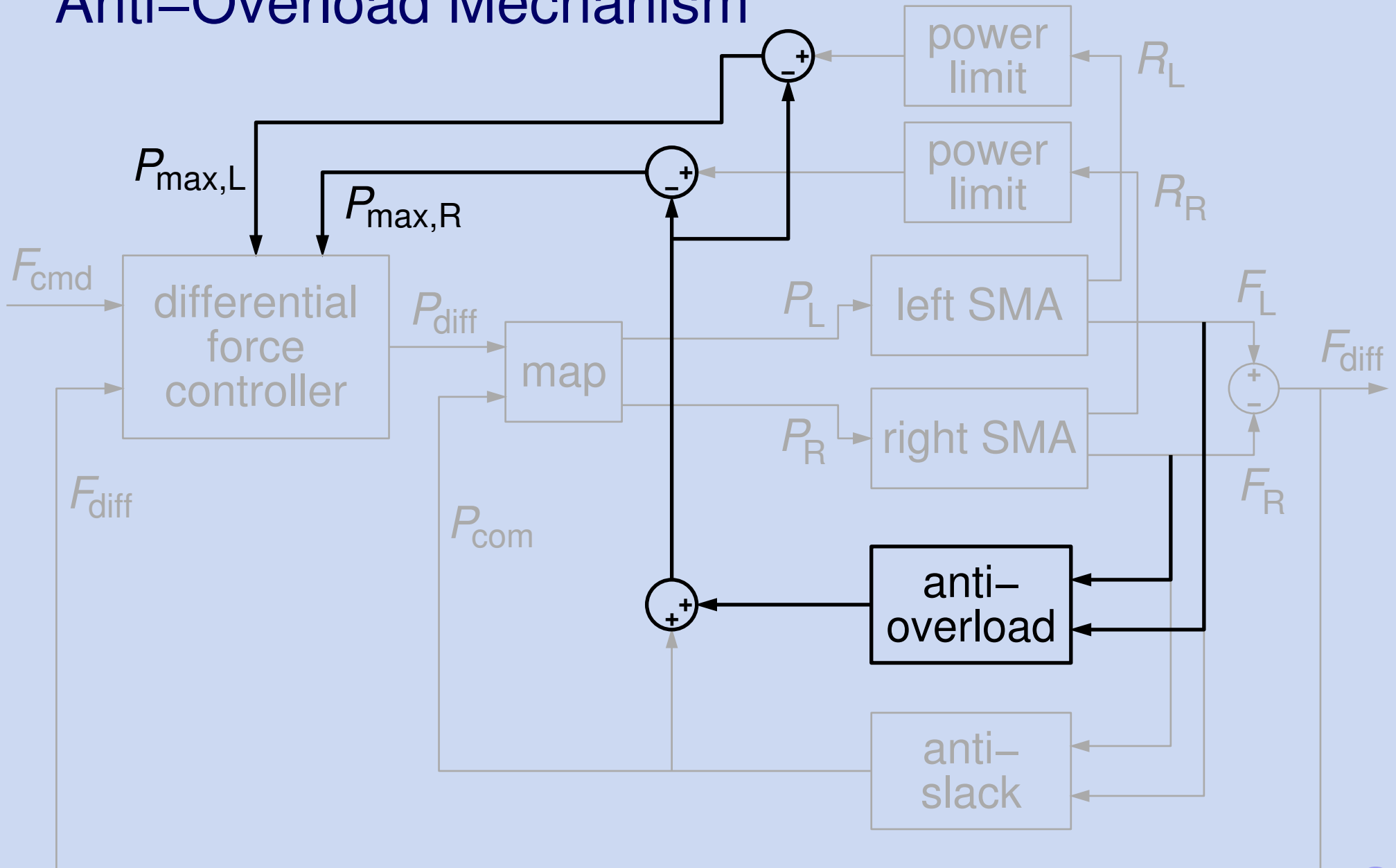

Anti-Overload Mechanism

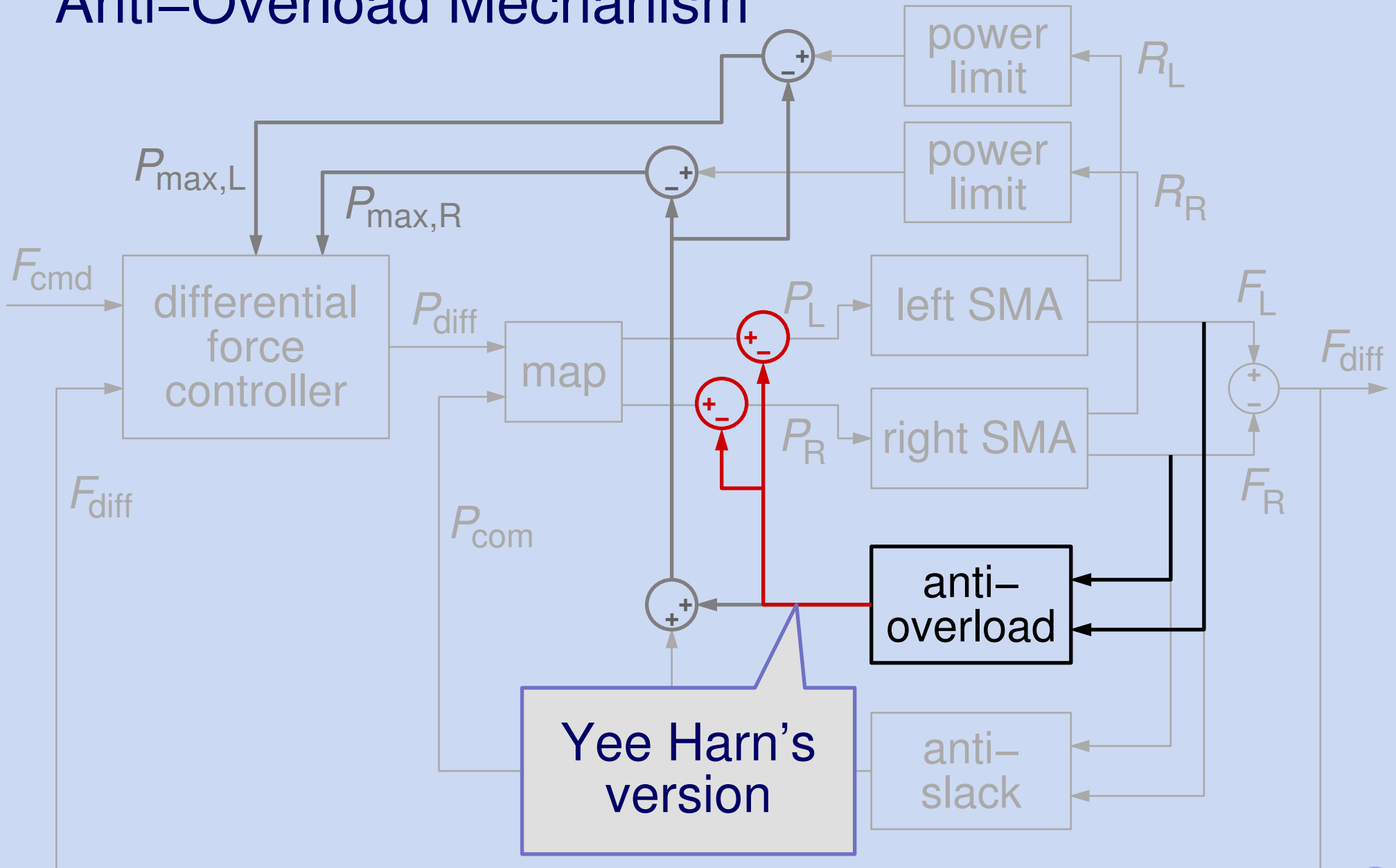

Anti-Overload Mechanism

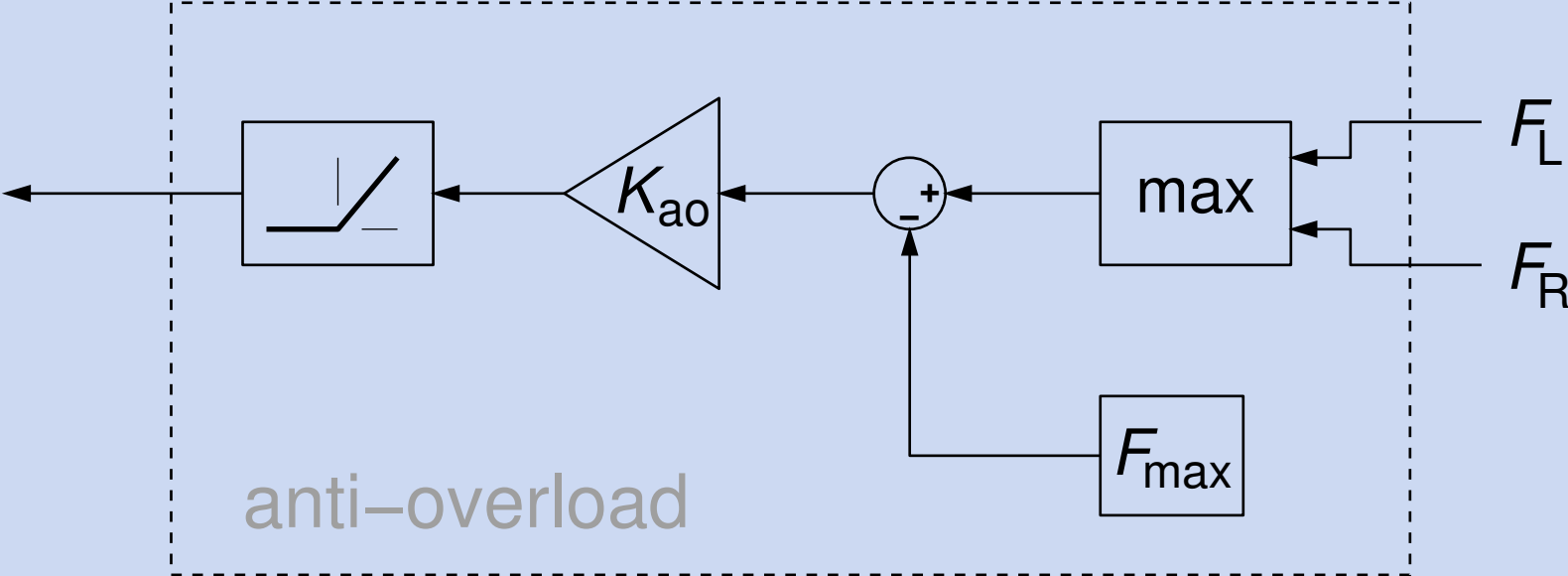

without anti-overload

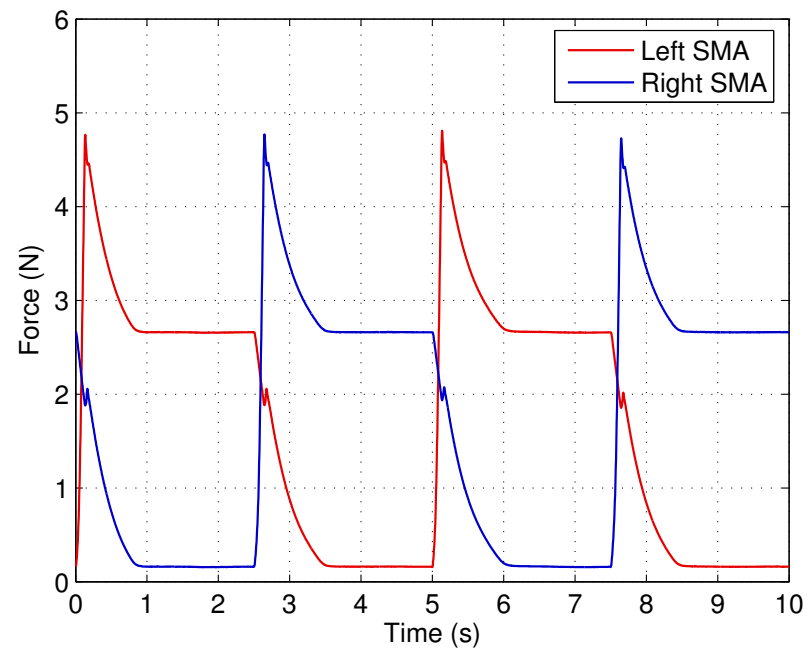
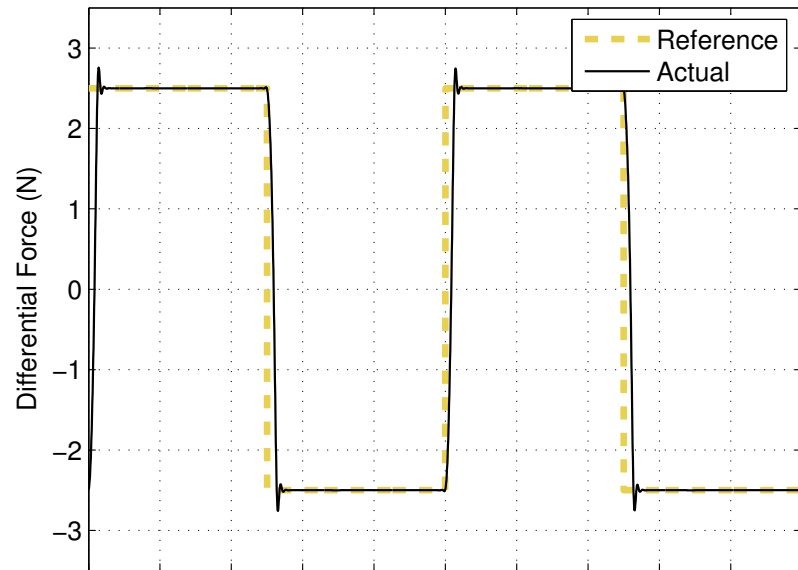

with anti-overload

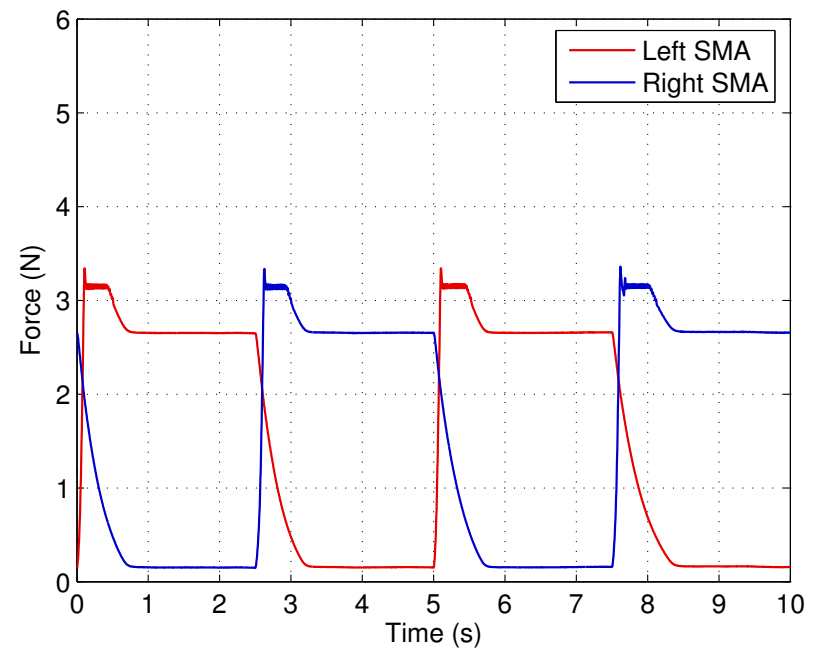
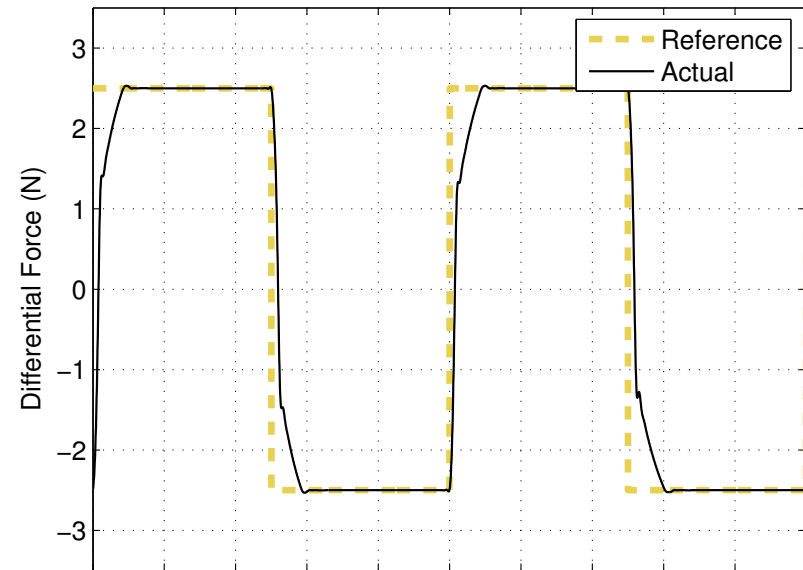

Conclusion

A new architecture for high-performance force control of antagonistic-pair SMA actuators has been presented, comprising

- a PID controller for accurate control of the actuator's output force (i.e., the differential force);
- an anti-slack mechanism to enforce a minimum tension on both wires;
- a rapid-heating mechanism that allows faster heating rates, but protects the wires from overheating; and
- an anti-overload mechanism that protects the wires from mechanical overload.

Epilogue

This control system has been found to work in the presence of large motion disturbances, and it has been used as the inner loop in a position control system that achieves high setpoint accuracy.

For more details, see

- Yee Harn's Ph.D. thesis
- Y. H. Teh & R. Featherstone, "An Architecture for Fast and Accurate Control of Shape Memory Alloy Actuators", *Int. J. Robotics Research*, 27(5):595–611, 2008.
- <http://users.rsise.anu.edu.au/~roy/SMA/>

Acknowledgement: The experimental results graphs appearing in this talk are taken from Yee Harn's Ph.D. thesis.