



## Technical Communique

Recursive identification of nonlinear plants operating in closed loop using kernel representations<sup>☆</sup>F. De Bruyne<sup>a, \*</sup>, B.D.O. Anderson<sup>b</sup>, I.D. Landau<sup>c</sup><sup>a</sup>Siemens, Service EIT ES (Advanced Process Control group), Building 15/0+, Demeurslaan 132, B1654 Huizingen, Belgium<sup>b</sup>Department of Systems Engineering, RSISE, The Australian National University, Canberra ACT 0200, Australia<sup>c</sup>Laboratoire d'Automatique de Grenoble (CNRS-INPG-UJF) ENSIEG, BP 46, 38402 Saint Martin d'Hères, France

Received 26 December 2000; received in revised form 13 April 2002; accepted 2 June 2002

## Abstract

In this paper, we extend the family of algorithms presented in Algorithms for identification of continuous time nonlinear systems. A passivity approach. In A. Isidori, F. Ramnabhi-Lagarigue, & W. Respondek (Eds.), Nonlinear control in the year 2000, vol. 2 (pp. 13–44) Berlin: Springer; (Automatica 37 (2000) 469) for the identification of continuous time nonlinear plants operating in closed loop. The new algorithms presuppose that one can construct a stable kernel representation for the “to be identified model” structure. The new theory results in a less restrictive passivity condition. The main novelty is that the identification of unstable plants can be tackled by an appropriate choice of the kernel representation, i.e. there is an additional degree of freedom when constructing the kernel representation. The implicit stability of the controller is still required by the new passivity condition. © 2002 Elsevier Science Ltd. All rights reserved.

**Keywords:** Closed-loop identification; Nonlinear systems; Adaptive systems; Output-error; Kernel representations

## 1. Introduction

One of the successful ways to develop algorithms for identification in closed loop in the linear context is to consider “closed-loop output error” (CLOE) schemes. A CLOE-type predictor parameterized in terms of the existing controller and the estimated plant is used. The algorithm minimizes a quadratic criterion in terms of the CLOE or drives the closed-loop output error to zero; see [Landau and Karimi (1997)] for results in a linear framework.

In Landau, Anderson, and De Bruyne (2000a,b), the authors derive several algorithms for the recursive identification of nonlinear plants operating in closed loop with a nonlinear controller using a CLOE identification scheme; this results in a nonlinear closed-loop output error (NL-CLOE) identification algorithm. As shown in Landau et al. (2000a), the identification of nonlinear unstable plants can be prevented by the passivity condition. Although a

variant of the algorithm for the identification of nonlinear unstable plants could be derived based on left coprime fractional descriptions, this theory would not be fully general as not every nonlinear plant has a left coprime fractional description. In this paper, we therefore extend the algorithm developed in Landau et al. (2000a,b) by using the notion of a kernel representation of a nonlinear system. As noted in Vander Schaft (1996), a stable kernel representation can be seen as a generalization of a left coprime factorization. Also, we have used the notion of a stable image representation to show the resemblance of our algorithm with the one derived in Landau and Karimi (1997) for the linear case.

The paper is organized as follows. Background material on stable kernel representations and stable image representations is presented in Section 2 and the problem setting is given in Section 3. In Section 4, the derivation of the algorithms is done in continuous time and in a deterministic noise free environment assuming that the plant is in the model set for a particular value of the unknown parameter vector and that one can neglect the terms of power higher than one in certain Taylor expansions. Section 5 connects the more general results derived in this paper with the ones derived in Landau et al. (2000a,b). Section 6 illustrates the theory with a simulation example. We conclude in Section 7.

<sup>☆</sup> This paper was not presented at any IFAC meeting. This paper was recommended for publication in revised form by Associate Editor Alf Isaksson under the direction of Editor Paul Van den Hof.

\* Corresponding author.

E-mail addresses: franky.de-bruyne@siemens.be, franky.debruyne@planetinternet.be (F. De Bruyne), brian.anderson@anu.edu.au (B.D.O. Anderson), ioan-dore.landau@inpg.fr (I.D. Landau).

## 2. Background material

A nonlinear generalization of the results in Landau et al. (2000b) hinges on a concept that generalizes the notion of a stable left coprime factorization of a nonlinear system. This generalization is provided by the notion of a stable kernel representation of a nonlinear system. We also use the notion of a stable image representation to show the similarity of our algorithm with the one derived in Landau and Karimi (1997). Kernel and image representations of a nonlinear system are described in Van der Schaft (1996).

For simplicity, let us consider affine systems of the type

$$P := \begin{cases} \dot{x} = f(x) + g(x)u, & x \in \mathcal{X}, u \in \mathbb{R}^m, \\ y = h(x), & y \in \mathbb{R}^p. \end{cases} \quad (2.1)$$

Suppose that  $P$  can be stabilized by an output-to-state feedback law  $k(x)$  with  $u$  and  $y$  an input–output trajectory pair. Then the system

$$z_l = G(u, y) \quad (2.2)$$

$$G = \begin{cases} \dot{x} = [f(x) - k(x)h(x)] + g(x)u + k(x)y, \\ z_l = y - h(x) \end{cases} \quad (2.3)$$

is a stable kernel representation of  $P$ . Here,  $z_l = 0$  means that  $u$  and  $y$  are trajectories of  $P$ . Of course when  $P$  is stable, one can choose  $k(\cdot) = 0$ . The construction above specialized to the linear case gives rise to a left coprime factorization; a nonlinear system kernel representation however does not normally yield a left coprime realization.

Also the system

$$\begin{bmatrix} y \\ u \end{bmatrix} = \begin{bmatrix} G_1 \\ G_2 \end{bmatrix} z_r = Gz_r, \quad (2.4)$$

$$G = \begin{cases} \dot{x} = [f(x) - g(x)k(x)] + g(x)z_r, \\ y = h(x), \\ u = z_r - k(x) \end{cases} \quad (2.5)$$

is a stable image representation of  $P$  with  $k(x)$  a stabilizing feedback law for  $P$ . The construction above specialized to the linear case gives rise to a right coprime factorization.

## 3. The basic equations and problem setting

The objective is to estimate the parameters of a single-input single-output (SISO) nonlinear time invariant system described by

$$S: y = P_0(u, v), \quad (3.1)$$

where  $P_0$  is an unknown causal nonlinear operator,  $u$  is the control input signal,  $y$  is the achieved output signal and  $v$  is the disturbance signal allowed to enter the system nonlinearly. It is not assumed that the output  $y$  can be expressed linearly in terms of some parameter vector  $\theta_0$ . For ease of

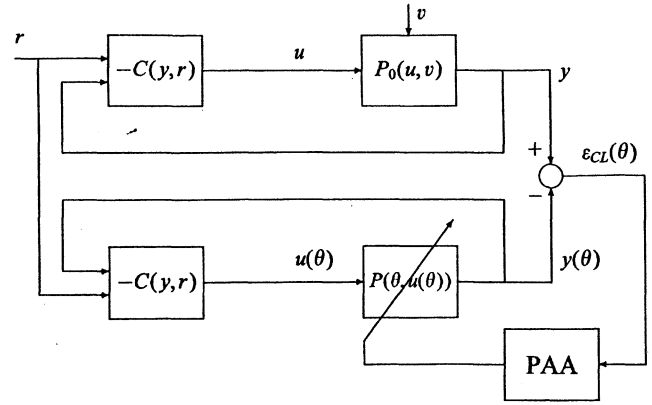

Fig. 1. Closed-loop output error identification scheme.

notation the time argument will be omitted when there are no ambiguities.

The plant is operated in closed loop with a known nonlinear controller, i.e.

$$C: u = -C(y, r), \quad (3.2)$$

where  $r$  is an external reference which is assumed to be quasi-stationary and uncorrelated with  $v$ . The controller  $C$  is a causal nonlinear operator acting on  $r$  and  $y$ .

The closed-loop operator from the measured reference signal  $r$  to the measured output signal  $y$ , as defined in Fig. 1, is denoted by

$$y = T_0(r, v). \quad (3.3)$$

It is required that the closed-loop system is bounded input bounded output (BIBO) stable.

We consider the following adjustable predictor for the closed-loop system defined by (3.1) and (3.2) (see also Fig. 1)

$$y(\theta) = P(\theta, u(\theta)), \quad (3.4)$$

$$u(\theta) = -C(y(\theta), r), \quad (3.5)$$

where  $P(\theta, u)$  defines the adjustable plant model,  $y(\theta)$  is the output of the closed-loop predictor and  $u(\theta)$  is the plant model input.

The closed-loop prediction error is defined as

$$\varepsilon_{CL} = y - y(\theta). \quad (3.6)$$

The following *assumptions* will be made in the sequel:

- (i)  $\exists \theta_0$  such that  $P(\theta_0, u) = P_0(u, 0)$  for all  $u \in \mathcal{L}_{2e}$ .
- (ii) The plant, the model, the controller, and all closed-loop operators are smooth functions of the reference signal, the input signal, the output signal and the disturbance signal. This means that if the closed-loop operator is linearized around any (stable) trajectory, the resulting linear (time-varying) system is BIBO stable. See Desoer and Vidyasagar (1975) for more details.

- (iii) One can construct for each  $\theta$  a stable kernel representation of

$$y_u(\theta) = P(\theta, u), \quad (3.7)$$

(see Section 2) as

$$z_l(\theta) = G(\theta, u, y_u(\theta)) \quad (3.8)$$

and the family is smooth in  $\theta$ .

- (iv) One can construct a stable image representation of

$$u = -C(y, r), \quad (3.9)$$

(see Section 2) as

$$\begin{bmatrix} u \\ y \\ r \end{bmatrix} = \begin{bmatrix} N \\ M \end{bmatrix} z_r, \quad (3.10)$$

where  $N$  and  $M$  are nonlinear operators in general. Note that if the controller is stable a trivial image representation is  $N = -C(\cdot)$ ,  $M = I$  ( $I$  is identity) and  $z_r = [y^T \ r^T]^T$ . This assumption is not necessary; it is introduced in order to show the resemblance of our algorithm with the one derived in Landau and Karimi (1997).

- (v) The operators  $\partial G_u(\theta, u, y)$  and  $\partial G_y(\theta, u, y)$  are the linearization of  $G(\theta, u, y)$ , respectively, in response to a perturbation in  $u$  and  $y$  along the trajectories produced by  $u$  and  $y$ .

The operators  $\partial N(z_r)$  and  $\partial M(z_r)$  are, respectively, the linearization of  $N(z_r)$  and  $M(z_r)$  in response to a perturbation in  $z_r = M^{-1}y$  along the trajectories produced by  $z_r$ .

It is assumed that the operators  $\partial G_u(\theta, u, y)$ ,  $\partial G_y(\theta, u, y)$ ,  $\partial N(z_r)$  and  $\partial M(z_r)$  exist for all allowable  $u$ ,  $y$  and  $r$ . They are linear time-varying operators along the trajectories of the closed-loop system.

Note that  $G$ ,  $N$  and  $M$  are stable operators. Using the smoothness assumptions made earlier, we can conclude that their linearization around any stable trajectory is BIBO stable.

- (vi) The partial derivative of  $G(\theta, u, y)$  with respect to  $\theta_j$  is denoted by  $G'_{\theta_j}(\theta, u, y)$  for  $j = 1, \dots, d$ , where  $d$  is the dimension of the parameter vector  $\theta$ .

The operator  $G'_{\theta_j}(\theta, u, y)$  and its time derivatives exist and are norm-bounded  $\forall j$  along the trajectories of the closed-loop predictor which requires  $\dot{r}$  to be bounded. This assumption is not particularly restrictive as  $P(\theta, \cdot)$  is assumed to be a smooth operator for all  $\theta$ .

- (vii) Let us define

$$P_{CL}(\theta) = [\partial G_y(\theta, u(\theta), y(\theta))\partial M(z_r(\theta)) + \partial G_u(\theta, u(\theta), y(\theta))\partial N(z_r(\theta))]. \quad (3.11)$$

It is assumed that  $P_{CL} = P_{CL}(\theta_0)$  and its inverse  $P_{CL}^{-1}$  exist along every trajectory of the closed-loop system

encountered during the identification process. Both operators are BIBO linear time-varying operators. Note that  $P_{CL}^{-1}$  is BIBO stable precisely because of the stability of the closed-loop system and the smoothness assumption on the closed-loop operator.

- (viii) The reference  $r$  and the stochastic disturbance  $v$  are independent.

Assumption (i) means that the plant is in the model set.

The assumptions presented here are essentially the same as the ones presented in Landau et al. (2000b); the additional restrictions are that one needs to be able to construct a smooth family of stable kernel representation for (3.7) and a stable image representation for (3.9).

The generic parameter adaptation algorithm (PAA) which will be used throughout the paper is the continuous time version of the general PAA used in Landau, Lozano and M'Saad (1997)

$$\dot{\theta}(t) = F(t)\phi(t)\varepsilon_{CL}(t), \quad (3.12)$$

$$\dot{F}^{-1}(t) = -[1 - \lambda_1(t)]F^{-1}(t) + \lambda_2(t)\phi(t)\phi^T(t)$$

$$0 < \lambda_1(t) \leq 1, \quad 0 \leq \lambda_2(t) < 2, \quad F(0) > 0,$$

$$F^{-1}(t) > \alpha F^{-1}(0), \quad 0 < \alpha < \infty, \quad (3.13)$$

where  $\theta(t)$  is the estimated parameter vector,  $\varepsilon_{CL}(t)$  is the closed-loop output error,  $\phi(t)$  is the observation vector,  $F(t)$  is the adaptation gain matrix,  $\lambda_1(t)$  is a time-varying forgetting factor and  $\lambda_2(t)$  allows one to weight the rate of decrease of the adaptation gain. The two functions  $\lambda_1(t)$  and  $\lambda_2(t)$  allow one to have different laws of evolution of the adaptation gain.

We will consider subsequently that the assumptions (i) through (vii) are valid and furthermore that  $v \equiv 0$ . This will allow us to implement the appropriate parameter estimation algorithm, i.e. it allows us to derive the observation vector  $\phi(t)$ .

#### 4. Nonlinear closed-loop output error identification using stable image and kernel representations

In this section, we present the main theorem of this paper. We will only provide the derivations of the algorithm. A stability analysis in a deterministic environment (assuming that the system can be modeled exactly and that one can neglect terms of power higher than one in certain Taylor series expansions) can easily be obtained by mimicking the proofs in Landau et al. (2000a,b).

One has the following result (NL-CLOE algorithm):

**Theorem 4.1.** *Under assumptions (i)–(vii), assuming that  $v(t) \equiv 0$  and neglecting the higher terms in certain Taylor expansions around the trajectories of the system one has*

for

$$\begin{aligned}\phi(t) &= [-G'(\theta, u(\theta), y(\theta))]^T \\ &= -[G'_{\theta_1}(\theta, u(\theta), y(\theta)) \cdots G'_{\theta_d}(\theta, u(\theta), y(\theta))]^T\end{aligned}$$

that

$$\lim_{t \rightarrow \infty} \varepsilon_{\text{CL}}(t) = 0 \quad (4.1)$$

if the linear time-varying operator

$$H = \partial M(z_r) P_{\text{CL}}^{-1} - \frac{\lambda(t)}{2} I, \quad \lambda(t) > \lambda_2(t) \quad \forall t \quad (4.2)$$

is strongly strictly passive.

If furthermore the linear time-varying operator  $P_{\text{CL}}^{-1}$  has a state-space representation (see Remark 1) one has also

$$\lim_{t \rightarrow \infty} \phi^T(t)(\theta(t) - \theta_0) = 0. \quad (4.3)$$

**Remark 1.**

1. It is assumed that  $P_{\text{CL}}^{-1}$  has a state-space representation  $\{A(t), B(t), C(t), D(t)\}$  with  $A(t)$ ,  $B(t)$ ,  $C(t)$  and  $D(t)$  continuous in  $t$ .
2. As the theorem proof will make clear, the Taylor series referred to in the theorem statement involve expansions in powers of  $(u - u(\theta))$ ,  $(y - y(\theta))$  and  $(\theta - \theta_0)$ .
3. Condition (4.2) assures that the prediction error goes asymptotically to zero, and that the estimated parameter vector  $\theta$ , converges to a set defined as

$$\mathcal{D}_c = \{\theta: \phi^T(t)(\theta - \theta_0) = 0\}. \quad (4.4)$$

If

$$\phi^T(t)(\theta - \theta_0) = 0 \quad (4.5)$$

has a unique solution  $\theta = \theta_0$ , the parameter vector will converge toward this value. In fact this condition is a “persistence of excitation” condition for the nonlinear case.

**Proof of Theorem 4.1.** In this paper, we provide Step 1 of the proof; Step 2 can easily be obtained by mimicking the proof in Landau et al. (2000a,b).

*Step I:* Establishing the expression  $\varepsilon_{\text{CL}} = \mathbf{f}(\theta_0 - \theta(t))$ . One has the following lemma:

**Lemma 4.1.** *Neglecting the higher order terms in the Taylor expansion around the trajectories of the closed-loop system and higher order terms in the Taylor expansion in powers of  $(\theta - \theta_0)$ , the closed-loop output error is given by*

$$\varepsilon_{\text{CL}} = \partial M(z_r) P_{\text{CL}}^{-1} [-G'(\theta, u(\theta), y(\theta))] [\theta_0 - \theta(t)]. \quad (4.6)$$

**Proof.** Let  $u$  and  $y$  denote trajectories from the closed-loop system (3.1) and (3.2) with  $v \equiv 0$ ; one gets  $y = P(\theta_0, u)$ .

From (3.8),  $z_l = G(\theta_0, u, y)$  is a stable kernel representation of  $P(\theta_0, u)$ . Note that  $z_l = 0$  as  $u$  and  $y$  are trajectories from  $y = P(\theta_0, u)$ . It follows that

$$\begin{aligned}z_l = 0 &= G(\theta_0, u, y) \\ &= G(\theta_0, u(\theta), y(\theta)) + [G(\theta_0, u, y) \\ &\quad - G(\theta_0, u(\theta), y(\theta))]\end{aligned} \quad (4.7)$$

and, using series expansions around  $u$  and  $y$  while neglecting higher order terms in  $(u - u(\theta))$  and  $(y - y(\theta))$ , one gets

$$\begin{aligned}G(\theta_0, u, y) - G(\theta_0, u(\theta), y(\theta)) \\ &= G(\theta_0, u, y) - [G(\theta_0, u, y) + \partial G_u(\theta_0, u, y)(u(\theta) - u) \\ &\quad + \partial G_y(\theta_0, u, y)(y(\theta) - y)] \\ &= \partial G_u(\theta_0, u, y)(u - u(\theta)) + \partial G_y(\theta_0, u, y)\varepsilon_{\text{CL}},\end{aligned}$$

where the definition of  $\varepsilon_{\text{CL}}$  given in (3.6) has been used. Using (3.10), it follows that

$$\begin{aligned}u - u(\theta) &= N(z_r) - N(z_r(\theta)) = \partial N(z_r)(z_r - z_r(\theta)), \\ y - y(\theta) &= M(z_r) - M(z_r(\theta)) = \partial M(z_r)(z_r - z_r(\theta))\end{aligned}$$

which yields

$$u - u(\theta) = \partial N(z_r) \partial M(z_r)^{-1} (y - y(\theta)). \quad (4.8)$$

It is now straightforward to see that

$$\begin{aligned}G(\theta_0, u, y) - G(\theta_0, u(\theta), y(\theta)) \\ &= [\partial G_y(\theta_0, u, y) + \partial G_u(\theta_0, u, y) \partial N(z_r) \partial M(z_r)^{-1}] \varepsilon_{\text{CL}}.\end{aligned}$$

It now follows that

$$\begin{aligned}G(\theta_0, u, y) &= G(\theta_0, u(\theta), y(\theta)) + [\partial G_y(\theta_0, u, y) \partial M(z_r) \\ &\quad + \partial G_u(\theta_0, u, y) \partial N(z_r)] \partial M(z_r)^{-1} \varepsilon_{\text{CL}}.\end{aligned}$$

Let  $y(\theta)$  and  $u(\theta)$  denote trajectories from the closed-loop system (3.4) and (3.5). From (3.8), it follows that  $z_l(\theta) = G(\theta, u(\theta), y(\theta))$  is a stable kernel representation of  $P(\theta, u(\theta))$ . Here,  $z_l(\theta) = 0$  as  $u(\theta)$  and  $y(\theta)$  are trajectories from  $y(\theta) = P(\theta, u(\theta))$ . Let us subtract  $G(\theta, u(\theta), y(\theta))$  from  $G(\theta_0, u, y)$ . One obtains

$$\begin{aligned}0 &= G(\theta_0, u, y) - G(\theta, u(\theta), y(\theta)) \\ &= G(\theta_0, u(\theta), y(\theta)) - G(\theta, u(\theta), y(\theta)) \\ &\quad + P_{\text{CL}} \partial M(z_r)^{-1} \varepsilon_{\text{CL}}, \\ &= G'(\theta, u(\theta), y(\theta))(\theta_0 - \theta) + P_{\text{CL}} \partial M(z_r)^{-1} \varepsilon_{\text{CL}}.\end{aligned}$$

from which one obtains

$$\varepsilon_{\text{CL}} = \partial M(z_r) [P_{\text{CL}}]^{-1} [-G'(\theta, u(\theta), y(\theta))] (\theta_0 - \theta).$$

Here,  $G'(\theta, u(\theta), y(\theta))$  has to be read as  $G'(\theta, u, y)|_{u=u(\theta), y=y(\theta)}$ .  $\square$

**Remarks.**

1. It can easily be seen that the results derived here simplify to the ones derived in Landau and Karimi (1997) for the linear case.
2. The passivity condition derived in this paper is less restrictive than the one derived in Landau et al. (2000a,b) as there is an additional degree of freedom when constructing the kernel representation. This is illustrated in Section 6 by using the example of Landau et al. (2000a).
3. Note that the passivity condition implies the stability of the controller; a similar observation had been made for the linear case in Landau and Karimi (1997).
4. One can also derive robustness results (that take into consideration the influence of noise, unmodeled dynamics and second order terms in the Taylor expansions) by mimicking the results obtained in Landau et al. (2000a,b).

**Variant on the algorithm.** By multiplying (4.6) with a time varying operator followed by its inverse, one obtains

$$\varepsilon_{CL} = \partial M(z_r) P_{CL}^{-1} P_{CL}(\theta) \partial M(z_r(\theta))^{-1} [-\partial M(z_r(\theta)) P_{CL}(\theta)^{-1} G'(\theta, u(\theta))][\theta_0 - \theta(t)]. \quad (4.9)$$

While this expression is perfectly valid for time invariant operators ( $\theta$  is constant), it is not exact in the case of time varying operators ( $\theta$  is not constant). In this later case one should add the “swapping terms” in this equation; see for example [Narendra and Annaswamy (1989)]. When doing system identification one usually use a “time decreasing adaptation gain”, i.e. asymptotically the adaptation gain goes to zero. This implies that asymptotically the variations of the estimated parameters will go to zero, i.e. the swapping terms can be neglected in practice.

With the variation on the algorithm, one has to choose

$$\phi(t) = -\partial M(z_r(\theta)) P_{CL}(\theta)^{-1} G'(\theta, u(\theta)). \quad (4.10)$$

In this case one filters  $G'(\theta, u(\theta))$  through a linear time-varying closed-loop system which depends upon the current estimate.

The corresponding strongly strictly passive condition will become

$$H = \partial M(z_r) P_{CL}^{-1} P_{CL}(\theta) \partial M(z_r(\theta))^{-1} - \frac{\lambda(t)}{2} I,$$

$$\lambda(t) > \lambda_2(t) \quad \forall t > t_0$$

should be strongly strictly passive for every  $\theta$  encountered during the identification procedure.

Clearly in the vicinity of  $\theta_0$ , this condition is much more likely to be satisfied than condition (4.2) for NL-CLOE. The preceding algorithm is the generalization of the AFNL-CLOE algorithm presented in Landau et al. (2000b).

**5. Connections with previous results**

In this section, we consider three special cases:

1. the controller is stable,
2. the plant has a left coprime factorization and the controller is stable, and
3. both the plant and the controller are stable.

(1) Suppose the controller is stable. Then one can choose (without loss of generality)  $N = -C(\cdot)$  and  $M = I$ . This yields

$$\varepsilon_{CL} = P_{CL}^{-1} [-G'(\theta, u(\theta), y(\theta))][\theta_0 - \theta(t)]$$

with

$$P_{CL} = [\partial G_y(\theta, u(\theta), y(\theta)) - \partial G_u(\theta, u(\theta), y(\theta)) \partial C_y(r, y)].$$

(2) Suppose that, in addition to  $C$  being stable, one can also construct a stable left coprime description of

$$y_u(\theta) = P(\theta, u) \quad (5.11)$$

(see Hammer (1987) for further details) as

$$D_l(\theta, y_u(\theta)) = N_l(\theta, u).$$

Thus,  $P = D_l^{-1} N_l$ . Then it follows that

$$z_l(\theta) = G(u, \dot{y}_u(\theta)) = D_l(\theta, y_u(\theta)) - N_l(\theta, u)$$

is a stable kernel representation of (5.11). It now follows that

$$\varepsilon_{CL} = P_{CL}^{-1} \phi(t)[\theta_0 - \theta(t)],$$

$$\begin{aligned} \phi(t) &= [-G'(\theta, u(\theta), y(\theta))]^T \\ &= [N_l'(\theta, u(\theta)) - D_l'(\theta, y(\theta))]^T \end{aligned}$$

$$\begin{aligned} P_{CL} &= [\partial G_y(\theta_0, u, y) - \partial G_u(\theta_0, u, y) \partial C_y(r, y)] \\ &= [\partial D_l(\theta_0, y) + \partial N_l(\theta_0, u) \partial C_y(r, y)]. \end{aligned}$$

(3) Suppose that, in addition to  $C$  being stable, (5.11) is a stable plant. Then it follows that

$$z_l(\theta) = G(u, y_u(\theta)) = y_u - P(\theta, u)$$

is a stable kernel representation of (5.11). It now follows that

$$\varepsilon_{CL} = P_{CL}^{-1} \phi(t)[\theta_0 - \theta(t)],$$

$$\phi(t) = [-G'(\theta, u(\theta), y(\theta))]^T = [P'(\theta, u(\theta))]^T,$$

$$\begin{aligned} P_{CL} &= [\partial G_y(\theta_0, u, y) - \partial G_u(\theta_0, u, y) \partial C_y(r, y)] \\ &= [I + \partial P_u(\theta_0, u) \partial C_y(r, y)] \end{aligned}$$

as originally derived in Landau et al. (2000b).

## 6. An example

In this section, we consider the same example as the one used in Landau et al. (2000a). However, in this paper, we will use it to illustrate the recursive identification of an unstable nonlinear plant. Consider a plant described by

$$\dot{x} = u + \theta_0 x^2, \quad (6.1)$$

$$y = x + v \quad (6.2)$$

with  $x, u, y$  in  $\mathbf{R}^1$ . Note that, contrary to what was done in Landau et al. (2000a), we do not impose any restrictions on  $\theta_0$ . We will also introduce a nonzero  $v$  to demonstrate the robustness of the algorithm.

Consider the BIBO stable controller

$$u = -(y^3 + by^2) + r = -C(y) + r. \quad (6.3)$$

Note that the controller is stable as it is memoryless. It is assumed that  $\theta_0$  is unknown but  $b$  is known. Observe that  $b$  might well be chosen as an estimate of  $\theta_0$ . For if  $b = \theta_0$  and  $v \equiv 0$ , the closed-loop system equation becomes

$$\dot{x} = -x^3 + r$$

and the closed-loop system is asymptotically stable.

The equations of the estimated closed-loop system are as follows: the estimated plant model will be described by

$$\dot{\hat{x}}(\theta) = u(\theta) + \theta x(\theta)^2, \quad (6.4)$$

$$y(\theta) = x(\theta) \quad (6.5)$$

and the estimated control will be given by

$$u(\theta) = -[y(\theta)^3 + by(\theta)^2] + r = -C(y(\theta)) + r. \quad (6.6)$$

A kernel representation of

$$\dot{\hat{x}}(\theta) = u + \theta x(\theta)^2, \quad (6.7)$$

$$y_u(\theta) = x(\theta) \quad (6.8)$$

is

$$G(\theta, u, y_u(\theta)): \begin{cases} \dot{\hat{x}}(\theta) = [\theta x(\theta)^2 - k(x(\theta))x(\theta)] \\ \quad + k(x(\theta))y_u(\theta) + u, \\ z_1(\theta) = y_u(\theta) - x(\theta), \end{cases}$$

where  $k(\cdot)$  is chosen such that

$$\dot{\hat{x}}(\theta) = [\theta x(\theta)^2 - k(x(\theta))x(\theta)] + q$$

is BIBO stable, with  $q$  as input.

One gets (with  $p = d/dt$ )

$$G'(\theta, u(\theta), y(\theta)) = [p - 2\theta y(\theta) + k(y(\theta))]^{-1} y(\theta)^2,$$

$$\partial G_u(\theta, u(\theta), y(\theta)) = -[p - 2\theta y(\theta) + k(y(\theta))]^{-1},$$

$$\begin{aligned} \partial G_u(\theta_0, u, y) &= \partial G_u(\theta_0, u(\theta_0), y(\theta_0)) \\ &= -[p - 2\theta_0 y + k(y)]^{-1}, \end{aligned}$$

$$\partial G_y(\theta, u(\theta), y(\theta)) = \frac{p - 2\theta y(\theta) + 2k(y(\theta))}{p - 2\theta y(\theta) + k(y(\theta))},$$

$$\partial G_y(\theta_0, u, y) = \frac{p - 2\theta_0 y + 2k(y)}{p - 2\theta_0 y + k(y)},$$

$$\partial C_y(r, y(\theta)) = 3y^2(\theta) + 2by(\theta),$$

$$\partial C_y(r, y) = \partial C_y(r, y(\theta_0)) = 3y^2 + 2by.$$

Here, we have used the formulae of Section 5 as the controller is BIBO stable. One can express now

$$P_{CL}(\theta) = \frac{p + [3y^2(\theta) - 2(\theta - b)y(\theta) + 2k(y(\theta))]}{p - 2\theta y(\theta) + k(y(\theta))},$$

$$P_{CL} = \frac{p + [3y^2 - 2(\theta_0 - b)y + 2k(y)]}{p - 2\theta_0 y + k(y)}.$$

The convergence condition requires that  $P_{CL}^{-1}(\theta_0) - \lambda/2$  be strongly strictly passive where  $P_{CL}(\theta)$  is given above. In this example, one should make the assumption that  $-2\theta_0 y + k(y) > 0 \forall t$ , as well as the assumption that  $3y^2 - 2(\theta_0 - b)y + 2k(y) > 0 \forall t \geq t_0$ . This can always be achieved using an appropriate choice of  $k(\cdot)$  in the kernel representation  $G$  defined above. Note that the results simplify to the ones obtained in Landau et al. (2000a) when  $k(\cdot) = 0$ .

Note that the old theory ( $k \equiv 0$ ) would have implied that, for  $\theta_0 > 0$ ,  $y(t) < 0$  for all  $t$ . We show below that the new theory can handle this situation with an appropriate choice of  $k$ .

We apply the NL-CLOE algorithm using the previous example with  $b = 0.4$ ,  $r = 2 + 0.5 \sin(0.1t)$  and  $v$  zero mean white Gaussian noise with variance  $\sigma^2$ . Note that this choice of reference signal yields a positive  $y(t)$ . The parameter which is to be identified recursively is given by

$$\theta_0(t) = \begin{cases} 0.5 & \text{for } t \leq 105, \\ 0.5 + 0.25 \sin(0.03t) & \text{for } t > 105, \end{cases} \quad (6.9)$$

i.e. the parameter  $\theta_0$  is first held constant and then allowed to vary sinusoidally. We adopt a least-squares strategy with forgetting factor ( $\lambda_1 = 0.5$ ,  $\lambda_2 = 1$ ) and the algorithm is initialized with  $\theta(0) = -0.5$ . Note that the open-loop system is unstable at all  $t$  whereas the initial  $\theta(0)$  corresponds to an open-loop stable model for  $x > 0$ . We have used a stable kernel representation  $G$  (as computed above) with  $k(\cdot) = 3[(\cdot)^2 + 1]$ . This choice of  $k(\cdot)$  ensures that the convergence condition is satisfied.

The top picture of Fig. 2 shows the identification results in a noiseless situation. The NL-CLOE algorithm allows a consistent identification of  $\theta_0$  with very good tracking results. The bottom picture of Fig. 1 shows the appearance of a systematic small bias on the estimate in a noisy situation with the NL-CLOE algorithm. The tracking results remain very good. Note that the sensitivity to noise can be improved (at the expense of the tracking performance) by increasing the value of  $\lambda_1$ .

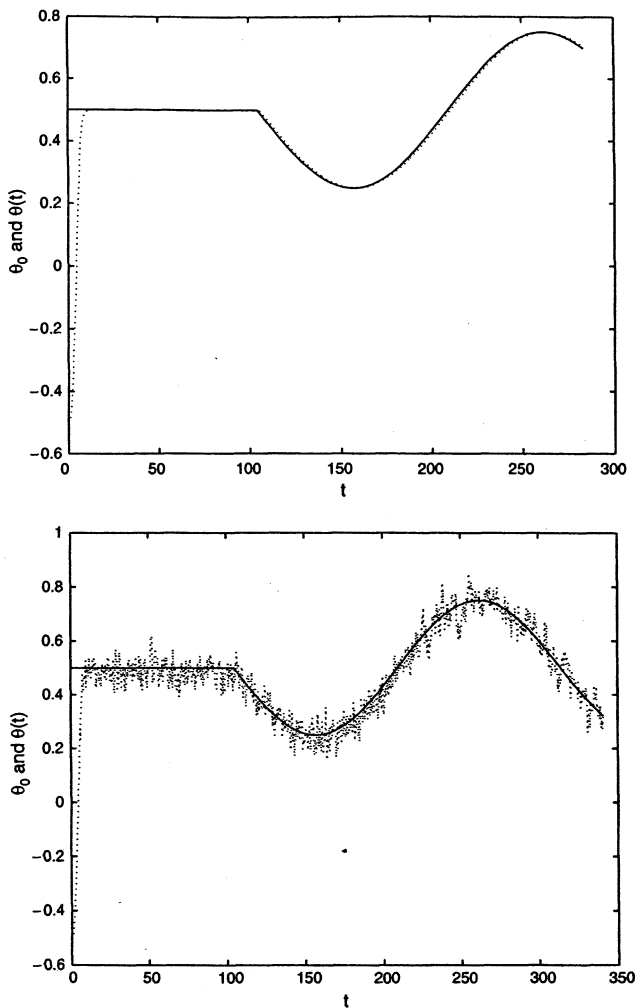

Fig. 2. Identification of  $\theta_0(t)$  (—) in a noiseless case ( $\sigma^2=0$ , top picture) and in a noisy situation ( $\sigma^2=0.01$ ,  $\lambda_1=0.5$  and  $\lambda_2=1$ , bottom picture) using the NL-CLOE (···) algorithm.

## 7. Conclusion

The main contribution of this paper is to extend the applicability of a number of closed-loop output-error

identification algorithms. Indeed, in the old theory presented in Landau et al. (2000a,b), the passivity condition implicitly imposes limitations on the stability of the plant and the controller.

With the new theory presented in this paper, only the stability of the controller is imposed by the new passivity condition; a clever choice of the kernel representation allows one to apply the algorithm for the closed-loop identification of any unstable nonlinear plant.

## Acknowledgements

B.D.O. Anderson wishes to acknowledge the funding of the US Army Research Office, Far East and the Office of Naval Research, Washington.

## References

- Desoer, C. A., & Vidyasagar, M. (1975). *Feedback systems: input and output properties*. Electrical Science Series. New York: Academic Press.
- Hammer, J. (1987). Fraction representations of nonlinear systems: A simplified approach *International Journal of Control*, 46, 455–472.
- Landau, I. D., Anderson, B. D. O., & De Bruyne, F. (2000a). Algorithms for identification of continuous time nonlinear systems. A passivity approach. In A. Isidori, F. Ramnabhi-Lagarrigue, & W. Respondek (Eds.), *Nonlinear control in the year 2000*, Vol. 2 (pp. 13–44) Berlin: Springer.
- Landau, I. D., Anderson, B. D. O., & De Bruyne, F. (2000b). Recursive identification algorithms for continuous time nonlinear plants operating in closed loop. *Automatica*, 37, 469–475.
- Landau, I. D., & Karimi, A. (1997). Recursive algorithms for identification in closed-loop: A unified approach and evaluation *Automatica*, 33, 1499–1523.
- Landau, I. D., Lozano, R., & M'Saad, M. (1997). *Adaptive control*. United Kingdom: Springer.
- Narendra, K. S., & Annaswamy, A. M. (1989). *Stable adaptive systems*. Englewood Cliffs, NJ: Prentice-Hall.
- Van der Schaft, A. (1996).  $L_2$ -Gain and passivity techniques in nonlinear control. In *Lecture notes in control and Information Sciences*, Vol. 218. London: Springer.