

B.D.O. Anderson

Department of Electrical and Computer Engineering
University of Newcastle,
New South Wales, 2308, Australia

Abstract

Multiple-input, multiple-output systems are considered which are linear, time-invariant and finite dimensional and which possess a decentralized fixed mode. A transfer function characterization of this property is developed, which allows characterization also of the degree of a fixed mode, this concept being given a meaningful definition in the course of the paper.

1. Introduction and Background

The concept of the decentralized fixed modes of a linear, time-invariant, finite-dimensional, multiple-input multiple-output system was introduced in [1]. Properties of systems with such modes were further explored in [2], and connections with a decentralized control problem are considered in [3-6]. The existence or otherwise of decentralized fixed modes is a pertinent question for systems with minimal state-variable (or matrix fraction) descriptions, and although the existence of fixed modes has hitherto been considered using state-variable or matrix fraction tools, the fact that the existence property is invariant under the usual transformations between minimal system descriptions means that the property is one possessed by the system transfer function matrix alone. The characterization of the property via the transfer function matrix is achieved in this paper.

Suppose a multiple-input, multiple-output, linear, time-invariant, finite-dimensional system is described by

$$[A_1(s)A_2(s)\dots A_m(s)] \begin{bmatrix} y_1 \\ \vdots \\ y_m \end{bmatrix} = [B_1(s)B_2(s)\dots B_m(s)] \begin{bmatrix} u_1 \\ \vdots \\ u_m \end{bmatrix} \quad (1.1)$$

where each y_i, u_j is a vector, and the $A_i(s), B_j(s)$ are polynomial matrices. Suppose further that (1.1) is minimal, i.e. there is no polynomial left divisor of $A_1(s), \dots, A_m(s), B_1(s), \dots, B_m(s)$ with nonconstant determinant. The system is said to have a decentralized fixed mode [1,2] if and only if for all real, constant k_i of appropriate dimension and some s_0 ,

$$\det[A_1(s_0) + B_1(s_0)k_1 \quad A_2(s_0) + B_2(s_0)k_2 \quad \dots \quad A_m(s_0) + B_m(s_0)k_m] = 0 \quad (1.2)$$

This means that for all feedbacks of the form $u_i = k_i y_i + v_i$ (with an external input), s_0 remains a mode of the system.* It is established in [2] that a necessary and sufficient condition for the existence of a fixed mode is that for some non-empty subset $\{i_1, \dots, i_\alpha\}$ of $\{1, 2, \dots, m\}$ and some s_0 ,

$$\text{rank} \begin{bmatrix} A_{i_1}(s_0) & A_{i_2}(s_0) & \dots & A_{i_\alpha}(s_0) & B_{i_1}(s_0) & \dots & B_{i_\alpha}(s_0) \\ \vdots & \vdots & & \vdots & \vdots & & \vdots \end{bmatrix} < \sum_{j=1}^{\alpha} (\text{number of columns of } A_{i_j}) \quad (1.3)$$

(A condition based on a state-variable system description is also available.) Our main goal will be to describe conditions on the system transfer function matrix for the existence of fixed modes. First, we note simple consequences of (1.3).

2. Consequences of the Fixed Mode Condition

By reordering of inputs and outputs if necessary, assume $i_j = j$ in (1.3). Write $A_1 = [A_1 \dots A_\alpha]$, $A_2 = [A_{\alpha+1} \dots A_m]$; $B_1, B_2, U_1, U_2, Y_1, Y_2$ have similar obvious definitions. Then (1.3) implies that

$$[A_1 \quad A_2] \begin{bmatrix} Y_1 \\ Y_2 \end{bmatrix} = [B_1 \quad B_2] \begin{bmatrix} U_1 \\ U_2 \end{bmatrix} \quad (2.1)$$

has a decentralized fixed mode at s_0 , i.e. the decentralized fixed mode for (1.1) remains for a wider class of feedback (y_j to u_i so long as $1 \leq i, j \leq \alpha$ or $\alpha+1 \leq i, j \leq m$) than the definition originally suggests. For (1.3) implies that for all K_1 of appropriate dimension, $\text{rank}[A_1(s_0) + B_1(s_0)K_1] < \text{number of columns of } A_1$, and the conclusion is then immediate.

Both conditions $\text{rank}[A_i(s_0) \quad B_i(s_0)] < \text{number of columns of } A_i$ for $i=1$ or 2 imply that (2.1) has fixed modes. What is the difference between these conditions? Suppose that in (2.1), we set $U_2 = K_2 Y_2$, thus producing a system with input U_1 , output Y_1 , such that

$$Y_1 = [I \quad 0][A_1 \quad A_2 + B_2 K_2]^{-1} B_1 U_1 \quad (2.2)$$

Then if the rank condition holds with $i=1$, simple

* It would perhaps be less misleading to call s_0 a fixed pole, or eigenvalue, of the system. However, the nomenclature fixed mode is more or less entrenched.

calculation shows $[A_1 A_2 + B_2 K_2]$ and B_1 fail to be left coprime; if it holds with $i=2$, $[I \ 0]$ and $[A_1 A_2 + B_2 K_2]$ fail to be right coprime. This means that if a minimal state-variable realization of (2.1) is constructed, and from it a realization of (2.2) by setting $U_2 = K_2 Y_2$, this realization has an uncontrollable or unobservable mode at s_0 according as $i=1$ or 2 in the rank condition. Subsequent application of feedback to u_1 via $u_1 = K_1 y_1 + v_1$ does not of course vary this conclusion. In fact, a more detailed analysis, see [2], shows that if (2.1) can be modelled by

$$\begin{aligned} \dot{x} &= Fx + G_1 U_1 + G_2 U_2 \\ Y_1 &= H_1^T x \quad Y_2 = H_2^T x \end{aligned} \quad (2.3)$$

then the two possibilities correspond to

$$\text{rank} \begin{bmatrix} s_0 I - F & G_1 \\ H_2 & 0 \end{bmatrix} < \dim F \quad \text{rank} \begin{bmatrix} s_0 I - F & G_2 \\ H_1 & 0 \end{bmatrix} < \dim F$$

3. A 2x2 Transfer Function Matrix with Single Pole at s_0

To obtain insight into the general problem, we shall consider a special case. Let $W(s)$ be 2x2 with $a(s)$ the characteristic polynomial. Write

$$W(s) = \begin{bmatrix} \frac{n_{11}}{a} & \frac{n_{12}}{a} \\ \frac{n_{21}}{a} & \frac{n_{22}}{a} \end{bmatrix} \quad (3.1)$$

Notice that a divides $n_{11}n_{22} - n_{12}n_{21}$. Let $m(s)$ be the quotient. Suppose also that $W(s) = A^{-1}(s)B(s)$ with

$$A(s) = \begin{bmatrix} a_{11}(s) & a_{12}(s) \\ a_{21}(s) & a_{22}(s) \end{bmatrix} \quad B(s) = \begin{bmatrix} b_{11}(s) & b_{12}(s) \\ b_{21}(s) & b_{22}(s) \end{bmatrix} \quad (3.2)$$

and $A(s), B(s)$ are left coprime.

If there is a fixed mode at s_0 , with reordering of inputs if necessary we have $a_{11}(s_0) = a_{21}(s_0) = b_{11}(s_0) = b_{21}(s_0) = 0$. Easy calculations based on expressing the $n_{ij}(s)$ and $a(s)$ in terms of the $a_{ij}(s)$ and $b_{ij}(s)$ show that

$$a(s_0) = n_{11}(s_0) = n_{22}(s_0) = m(s_0) = 0$$

and

$$n_{21}(s_0) = \left. \frac{d}{ds} n_{21}(s) \right|_{s=s_0} = 0$$

while $n_{12}(s_0) \neq 0$ -else $a(s)$ would fail to be the characteristic polynomial. Therefore, if s_0 is a simple pole of $W(s)$, we have, after cancellations,

$$W(s) = \begin{bmatrix} \text{entry with no pole at } s_0 & \text{entry with pole at } s_0 \\ \text{entry with zero at } s_0 & \text{entry with no pole at } s_0 \end{bmatrix} \quad (3.3)$$

The converse is easy to establish: if there is a simple pole s_0 of $W(s)$ such that $W(s)$ has the structure (3.3), then s_0 is a fixed mode, with $\text{rank}[A_1(s_0)B_1(s_0)] = 0$; thus loop closing via $u_2 = k_2 y_2$ of a minimal realization of $W(s)$ will give an uncontrollable system. If the 1-2 and 2-1 entries of $W(s)$ are reversed, there is also a fixed mode; loop closing via $u_2 = k_2 y_2$ gives an unobservable system. Figure 1 illustrates the first situation; the pole-zero cancellation associated with the controllability is evident.

In summary, we have

Proposition 1: Consider a 2-input, 2-output system with rational transfer function matrix $W(s)$, and with a simple pole at s_0 . Then there is a decentralized fixed mode at s_0 if and only if $W(s)$ or its transpose has the form of the right side of (3.3).

This proposition was suggested to us by work of Wolovich [7], which is concerned with examining the effect of feedback on the sets of states reachable or observable from a single input or output in a multi-input, multi-output system.

The illustration of Figure 1 provides an interesting interpretation of a main result of [6]: according to [6], decentralized fixed modes can be eliminated with time-varying k_2 , given the satisfaction of certain connectivity conditions. The right-hand diagram of Fig. 1 shows that with k_2 time-varying, the pole-zero cancellation at s_0 , the cause of the fixed mode, will no longer occur. The diagram also illustrates a result of [1], extended in [2], to the effect that if k_2 is replaced by a transfer function $k_2(s)$, the fixed mode is still present -- as the diagram indicates, the pole-zero cancellation still occurs.

Another point illustrated by the diagram is the comparatively trivial nature of the Proposition in case $w_{21}(s) = 0$ (or, dually, $w_{12}(s) = 0$). On the other hand, if $w_{12}(s)w_{21}(s) \neq 0$ and $W(s)$ is strictly proper, the Proposition indicates that $W(s)$ must have at least 3 poles (2 of which may coincide, but not at s_0).

How may one remove the restriction that s_0 be a simple pole in the above Proposition? Extension of the argument above will establish the following result, which is subsumed by a later result for systems with more than 2 inputs or outputs.

Proposition 2: Consider a 2-input, 2-output system with rational transfer function matrix $W(s)$. Then there is a decentralized fixed mode at s_0 if and only if the greatest order which s_0 has as a pole of w_{11}, w_{22} and $|W|$ is less than the order it has as a pole of one of w_{12}, w_{21} .

As an example, consider

$$W(s) = \begin{bmatrix} 1/s + 1 & 1/s \\ 2 & 2/s \end{bmatrix}$$

Before exhibiting the generalization of (3.3), however, we shall discuss the degree of a fixed mode.

4. The Degree of a Fixed Mode

With notation as in Sections 1 and 2, suppose that

$$\text{rank}[A_1(s_0)B_1(s_0)] < \beta = \text{number of columns in } A_1 \quad (4.1)$$

Define the degree of the associated fixed mode as the largest positive integer k such that all $\beta \times \beta$ minors of $[A_1(s) B_1(s)]$ have a zero at s_0 of order at least k . (It is not hard to see that this definition is independent of the particular choice of minimal left matrix fraction description). This definition has the following significance.

Theorem 1: With notation as above, $\det[A_1(s) + B_1(s)K_1 : A_2(s) + B_2(s)K_2]$ has a zero at s_0 of order precisely k for almost all K_1, K_2 .

Proof: Suppose that $B_1(s), A_2(s), B_2(s)$ have $\gamma, \bar{\beta}$ and $\bar{\gamma}$ columns, respectively. Define column vectors $a_i(s), i=1, \dots, \beta+\bar{\beta}$ and $b_i(s), i=1, \dots, \gamma+\bar{\gamma}$ and scalars $k_{ij}, 1 \leq i \leq \gamma, 1 \leq j \leq \beta$ and $\gamma+1 \leq i \leq \gamma + \bar{\gamma}, \beta+1 \leq j \leq \beta + \bar{\beta}$, by

$$A_1(s) = [a_1(s) \dots a_\beta(s)] \quad A_2(s) = [a_{\beta+1}(s) \dots a_{\beta+\bar{\beta}}(s)]$$

$$B_1(s) = [b_1(s) \dots b_\gamma(s)] \quad B_2(s) = [b_{\gamma+1}(s) \dots b_{\gamma+\bar{\gamma}}(s)]$$

$$K_1 = \begin{bmatrix} k_{11} & \dots & k_{1\beta} \\ \vdots & & \vdots \\ k_{\gamma 1} & \dots & k_{\gamma\beta} \end{bmatrix} \quad K_2 = \begin{bmatrix} k_{\gamma+1, \beta+1} & \dots & k_{\gamma+1, \beta+\bar{\beta}} \\ \vdots & & \vdots \\ k_{\gamma+\bar{\gamma}, \beta+1} & \dots & k_{\gamma+\bar{\gamma}, \beta+\bar{\beta}} \end{bmatrix}$$

Observe, then, that

$$\det[A_1(s) + B_1(s)K_1 : A_2(s) + B_2(s)K_2]$$

$$= \det \left[a_1(s) + \sum_{i=1}^{\gamma} b_i(s)k_{i1} \dots a_\beta(s) + \sum_{i=1}^{\gamma} b_i(s)k_{i\beta} \right. \\ \left. a_{\beta+1}(s) + \sum_{i=\gamma+1}^{\gamma+\bar{\gamma}} b_i(s)k_{i, \beta+1} \dots a_{\beta+\bar{\beta}}(s) + \sum_{i=\gamma+1}^{\gamma+\bar{\gamma}} b_i(s) \right. \\ \left. k_{i, \beta+\bar{\beta}} \right]$$

= Sum of determinants with second through $\beta+\bar{\beta}$ columns identical to the above, and with first columns $a_1(s), b_1(s)k_{11}, b_2(s)k_{21}, \dots, b_\gamma(s)k_{\gamma 1}$.

The last expression is obtained by using the additive decomposition of the first column. Similarly, we may use the additive decomposition of all other columns to obtain an expression in the form of a sum of a very large number of determinants, and in the first β columns of each determinant, β columns of the set $a_1(s), \dots, a_\beta(s), b_1(s), \dots, b_\gamma(s)$ appear. By the definition of degree every $\beta \times \beta$ minor formed from the first β columns of each summand has a zero at s_0 of order at least k , so each summand, and thus the overall sum, has this property.

To complete the proof of the theorem, we must show that for almost all K_1, K_2 , the quantity $\det[A_1(s) + B_1(s)K_1 : A_2(s) + B_2(s)K_2]$ has a zero at

s_0 of order no greater than k . Clearly, it is enough to show this for one particular K_1, K_2 .

By the degree definition and the Cauchy-Binet Theorem [8, see pp. 9-12], all $\beta \times \beta$ minors of

$$[A_1(s) B_1(s)] \begin{bmatrix} L_1 \\ K_1 \end{bmatrix} = A_1(s)L_1 + B_1(s)K_1$$

have a zero at s_0 of order at least k , and for one choice of L_1, K_1 , at least one minor will have a zero of order precisely k . Hence, for almost all L_1, K_1 this will be the case. Hence, for almost all L_1, K_1 with nonsingular L_1 , this will be the case. Hence, for almost all K_1 , $A_1(s) + B_1(s)K_1$ will have at least one $\beta \times \beta$ minor with a zero at s_0 of order precisely k . Denote the set of such K_1 by V_1 .

A similar argument based on the Cauchy-Binet theorem and (4.1) shows that for almost all K_1 ,

$$\text{rank}[A_1(s_0) + B_1(s_0)K_1] = \text{rank}[A_1(s_0) B_1(s_0)]$$

Denote the set of such K_1 by V_2 .

Choose $K_1 \in V_1 \cap V_2$. Suppose that a unimodular transformation $U(s)$ acts on $[A(s) B(s)]$ to produce $U(s)[A(s) B(s)] = [\hat{A}(s) \hat{B}(s)]$ with

$$[\hat{A}_1(s) + \hat{B}_1(s)K_1] = \begin{bmatrix} M(s) \\ 0 \end{bmatrix}$$

where $M(s)$ is $\beta \times \beta$. Suppose further (and without loss of generality) that

$$M(s_0) = \begin{bmatrix} M_1 \\ 0 \end{bmatrix}$$

where M_1 has full rank. Since $\text{rank}[\hat{A}_1(s_0) \hat{B}_1(s_0)] = \text{rank}[\hat{A}_1(s_0) + \hat{B}_1(s_0)K_1]$, span of $[\hat{A}_1(s_0) \hat{B}_1(s_0)] = \text{span of } [\hat{A}_1(s_0) + \hat{B}_1(s_0)K_1]$; therefore, since $[\hat{A}(s_0) \hat{B}(s_0)]$ has full rank by coprimeness,

$$\begin{bmatrix} M_1 & & \\ \vdots & \hat{A}_2(s_0) & \hat{B}_2(s_0) \\ 0 & & \end{bmatrix}$$

has full rank, viz. $\beta + \bar{\beta}$. Hence, the last $\bar{\beta}$ rows of $[\hat{A}_2(s_0) \hat{B}_2(s_0)]$ have full rank; then for almost all K_2 , the last β rows of the $(\beta + \bar{\beta}) \times \bar{\beta}$ matrix $[\hat{A}_2(s_0) + \hat{B}_2(s_0)K_2]$ have full rank. Now write

$$[\hat{A}_1(s) + \hat{B}_1(s)K_1 \hat{A}_2(s) + \hat{B}_2(s)K_2] = \begin{bmatrix} M(s) & N(s) \\ 0 & P(s) \end{bmatrix} \begin{matrix} \beta \\ \bar{\beta} \end{matrix}$$

where $P(s_0)$ has full rank. It follows that $\det[A_1 + B_1K_1 : A_2 + B_2K_2]$ has a zero at s_0 of the same order as the zero of $\det M(s)$, viz. k . This proves the result.

Note that if (4.1) holds, it is impossible to have simultaneously

$$\text{rank}[A_2(s_0) \ B_2(s_0)] < \beta \quad (4.2)'$$

without violating the coprimeness requirement on $[A(s) \ B(s)]$. So the zeros of $\det[A_1 + B_1 K_1 : A_2 + B_2 K_2]$ can be due to one only of conditions (4.1) or (4.2).

5. Characterisation of Fixed Modes for an Arbitrary Transfer Function Matrix

In this section, we shall use the following standard notation. For a matrix X ,

$$X \begin{pmatrix} i_1 & \dots & i_p \\ k_1 & \dots & k_p \end{pmatrix} = \text{minor formed from rows } i_1, \dots, i_p \text{ and columns } k_1, \dots, k_p \text{ of } X \text{ (normally ordered with } i_1 < i_2 < \dots < i_p, k_1 < k_2 < \dots < k_p).$$

The main result is as follows.

Theorem 2: Suppose that with reordering of inputs and outputs we have

$$W(s) = \begin{bmatrix} W_{11}(s) & W_{12}(s) \\ W_{21}(s) & W_{22}(s) \end{bmatrix}$$

$$Y_i(s) = \sum_{j=1,2} W_{ij}(s) U_j(s) \quad (5.1)$$

and we consider control structures of the form $U_j = K_j Y_j + V_j, j=1, 2$. Suppose that $W_{11}(s)$ has β rows and $W_{21}(s)$ has β rows and let $a(s)$ be the characteristic polynomial of $W(s)$. The following two conditions are equivalent:

1. With $[A_1(s) \ A_2(s)]^{-1} [B_1(s) \ B_2(s)]$ a left coprime matrix fraction description of $W(s)$,

$$\text{rank}[A_1(s_0) \ B_1(s_0)] < \beta \quad (5.2)$$

and the fixed mode s_0 has degree k .

2. Suppose $a(s_0)$ has a zero of order κ .

Let $\# \begin{pmatrix} i_1 & \dots & i_p \\ \ell_1 & \dots & \ell_p \end{pmatrix}$ denote the number of zeros at s_0 of

$$W \begin{pmatrix} i_1 & \dots & i_p \\ \ell_1 & \dots & \ell_p \end{pmatrix}$$

with $\# = 0$ corresponding to no poles or zeros, $\# < 0$ corresponding to there being $-\#$ poles at s_0 , and $\# = \infty$ corresponding to a minor which is identically zero. Let $m = \beta + \beta$ and

$$\delta_r \begin{pmatrix} i_1 & \dots & i_p \\ \ell_1 & \dots & \ell_p \end{pmatrix} = |\{i'_1, \dots, i'_{m-p}\} \cap \{1, \dots, \beta\}| \quad (5.3)$$

where $\{i_1, i_2, \dots, i_p\} \cup \{i'_1, \dots, i'_{m-p}\} =$

$\{1, 2, \dots, m\}$, and

$$\delta_c \begin{pmatrix} i_1 & \dots & i_p \\ \ell_1 & \dots & \ell_p \end{pmatrix} = |\{\ell_1, \dots, \ell_p\} \cap \{1, \dots, \gamma\}| \quad (5.4)$$

Then there exists $0 < k \leq \kappa$ such that whenever $\delta_r + \delta_c \geq \beta$.

$$\# \begin{pmatrix} i_1 & \dots & i_p \\ \ell_1 & \dots & \ell_p \end{pmatrix} \geq (k - \kappa) + (\delta_r + \delta_c - \beta) \quad (5.5)$$

If $\kappa > k$, equality occurs in (5.5) for at least one choice of $i_1, \dots, i_p, \ell_1, \dots, \ell_p$ where $\delta_r + \delta_c = \beta$.

Remark: Before proving the Theorem, let us interpret the result. Broadly speaking, the result says that there is a fixed mode of degree k if and only if certain minors have s_0 as a zero of certain minimum order, or a pole of limited multiplicity, while at the same time, s_0 must be a pole of $W(s)$. In more detail, the quantity δ_r computes the number of rows in the first β rows of $W(s)$ which are not in the minor under scrutiny, while δ_c computes the number of columns in the first γ columns of $W(s)$ which are in the minor under scrutiny. The quantity $\delta_r + \delta_c - \beta$ therefore is associated with the position of the minor; large minors located inside $W_{21}(s)$ give the large values for this quantity, small minors located inside $W_{12}(s)$ give the small values. When this quantity is nonnegative, the behaviour of the minor at s_0 is constrained—see (5.5). Besides $\delta_r + \delta_c - \beta$, the constraint is affected by k , the degree of the fixed mode, and κ , the order which s_0 has as a zero of the characteristic polynomial of $W(s)$. If $\delta_r + \delta_c - \beta$ is negative, no special constraint is imposed; but note that if s_0 is a zero of the characteristic polynomial of order κ , there always exists at least one minor of $W(s)$ with s_0 as a pole of multiplicity κ .

Proof: Assume 1 holds. Let $C = A^{-1}$. As is well known, Jacobi's Theorem states [8, see p. 21]

$$C \begin{pmatrix} i_1 i_2 \dots i_p \\ k_1 k_2 \dots k_p \end{pmatrix} = (-1)^{\sum_{j=1}^p (i_j + k_j)} \frac{A \begin{pmatrix} k'_1 k'_2 \dots k'_{m-p} \\ i'_1 i'_2 \dots i'_{m-p} \end{pmatrix}}{|A|} \quad (5.6)$$

where $i_1 < i_2 < \dots < i_p$ and $i'_1 < i'_2 < \dots < i'_{m-p}$ form a complete system, i.e. $\{i_1, i_2, \dots, i_p\} \cup \{i'_1, i'_2, \dots, i'_{m-p}\} = \{1, 2, \dots, m\}$ and similarly for the k'_i, k'_j . Without loss of generality, $|A| = a(s)$. Now by the Cauchy-Binet theorem, [8],

$$(A^{-1}B) \begin{pmatrix} i_1 i_2 \dots i_p \\ \ell_1 \ell_2 \dots \ell_p \end{pmatrix} = \sum_{k_1 < k_2 < \dots < k_p} C \begin{pmatrix} i_1 i_2 \dots i_p \\ k_1 k_2 \dots k_p \end{pmatrix} B \begin{pmatrix} k_1 k_2 \dots k_p \\ \ell_1 \ell_2 \dots \ell_p \end{pmatrix}$$

K_1 and K_2 , contradicting Theorem 1. So $\kappa > k$ implies one or more of the minors for which $\delta_r + \delta_c = \beta$ has a zero of order precisely k .

It remains to establish the claim for $\delta_r + \delta_c > \beta$. If $\delta_r + \delta_c = \beta + 1$, the derivative (with respect to \bar{s}) of the determinant appearing as the numerator on the right of (5.7) is expressible as a sum of determinants with β columns drawn from $[A_1(s); B_1(s)]$, and so has a k -th order zero at s_0 . Also, the determinant itself obviously has a zero at s_0 . Hence the determinant has a $(k+1)$ -th order zero at s_0 . More generally, extension of the argument shows that if $\delta_r + \delta_c = \beta + q$ for $q > 1$, $\det[a_{i_1}(s) \dots a_{i_{m-p}}(s) b_{l_1}(s) \dots b_{l_p}(s)]$ has a $(k+q)$ -th order zero at s_0 . Conclusion 2 is now established.

Now assume 2 holds. Using the hypothesis and (5.7) it follows that every determinant of the form $\det[a_{i_1}(s) \dots a_{i_{m-p}}(s) b_{l_1}(s) \dots b_{l_p}(s)]$ with at least β columns drawn from $[A_1(s); B_1(s)]$ is zero at s_0 , and so $\det[A_1(s_0) + B_1(s_0)K_1, A_2(s_0) + B_2(s_0)K_2]$ is zero for all K_1, K_2 . Hence either

$$\text{rank}[A_1(s_0) \ B_1(s_0)] < \beta \text{ or} \\ \text{rank}[A_2(s_0) \ B_2(s_0)] < m - \beta = \bar{\beta} \quad (5.8)$$

but not both, else $\text{rank}[A(s_0) \ B(s_0)] < m$, contradicting coprimeness. To obtain a contradiction, suppose that $\text{rank}[A_1(s_0) \ B_1(s_0)] = \delta \geq \beta$. Choose δ columns from $[A_1(s_0) \ B_1(s_0)]$ and a further $m - \delta$ columns from $[A_2(s_0) \ B_2(s_0)]$ to form a non-singular matrix, and with this selection of columns associate a minor of $W(s)$ via (5.7). For this number, $\delta_r + \delta_c = \delta \geq \beta$, while the choice of columns ensures, see the right side of (5.7), that the # number for the minor = $-\kappa$, contradicting (5.5). Thus the first alternative in (5.8) holds. Let k' be the degree of the fixed mode at s_0 . Then, since we establish that condition 1 implies condition 2, either

$$\min_{\delta_r + \delta_c \geq \beta} \# \begin{pmatrix} i_1 \dots i_p \\ l_1 \dots l_p \end{pmatrix} = k' - \kappa \text{ and } k' < \kappa \quad (5.9a)$$

or

$$\min_{\delta_r + \delta_c \geq \beta} \# \begin{pmatrix} i_1 \dots i_p \\ l_1 \dots l_p \end{pmatrix} \leq k' - \kappa \text{ and } k' = \kappa \quad (5.9b)$$

Since condition 2 holds, either

$$\min_{\delta_r + \delta_c \geq \beta} \# \begin{pmatrix} i_1 \dots i_p \\ l_1 \dots l_p \end{pmatrix} = k - \kappa \text{ and } k < \kappa \quad (5.9c)$$

or

$$\min_{\delta_r + \delta_c \geq \beta} \# \begin{pmatrix} i_1 \dots i_p \\ l_1 \dots l_p \end{pmatrix} \geq k - \kappa \text{ and } k = \kappa \quad (5.9d)$$

Finally, (5.9a) and (5.9c) imply $k = k'$; (5.9b) and (5.9d) also imply $k = k'$; (5.9a) and (5.9d)

$$= \sum_{k_1 < k_2 < \dots < k_p} (-1)^{j=1} \binom{p}{i_j + k_j} \frac{1}{a(s)} A \begin{pmatrix} k'_1 & k'_2 & \dots & k'_{m-p} \\ i'_1 & i'_2 & \dots & i'_{m-p} \end{pmatrix} B \begin{pmatrix} k_1 & k_2 & \dots & k_p \\ l_1 & l_2 & \dots & l_p \end{pmatrix}$$

since

$$\sum_{j=1}^p i_j + \sum_{j=1}^{m-p} i'_j = \sum_{j=1}^m j = \frac{1}{2}m(m+1)$$

and similarly for the k_j , we have

$$(-1)^{j=1} \binom{p}{i_j + k_j} \binom{m-p}{i'_j + k'_j} = (-1)^{j=1} \binom{m-p}{i'_j + k'_j}$$

Then from the Laplace expansion formula, see [8, p. 22],

$$(A^{-1}B) \begin{pmatrix} i_1 & i_2 & \dots & i_p \\ l_1 & l_2 & \dots & l_p \end{pmatrix} = \frac{1}{a(s)} \det[a_{i'_1}(s) \dots a_{i'_{m-p}}(s) b_{l_1}(s) \dots b_{l_p}(s)] \quad (5.7)$$

(Here, $a_i(s)$ denotes the i -th column of $a(s)$, and similarly for $b_i(s)$).

Now recalling the definitions of δ_r and δ_c , we see that

$$\delta_r \begin{pmatrix} i_1 \dots i_p \\ l_1 \dots l_p \end{pmatrix} + \delta_c \begin{pmatrix} i_1 \dots i_p \\ l_1 \dots l_p \end{pmatrix} = \text{number of columns in determinant on right side of (5.7) drawn from columns of } \{A(s); B_1(s)\}$$

Now every $\beta \times \beta$ minor of $\{A_1(s); B_1(s)\}$ has a zero of order at least k at s_0 . Since

$$a(s) = |A(s)| = |A_1(s)A_2(s)| \\ = \sum_{k_1 < k_2 < \dots < k_p} (-1)^\eta A_1 \begin{pmatrix} k_1 & k_2 & \dots & k_p \\ 1 & 2 & \dots & \beta \end{pmatrix} A_2 \begin{pmatrix} \beta+1 & \beta+2 & \dots & m \\ k'_1 & k'_2 & \dots & k'_{m-p} \end{pmatrix}$$

where η is unimportant) we see that $a(s)$ has a zero at s_0 of order at least k . Then $\kappa \geq k$. Also if

$$\delta_r + \delta_c = \beta$$

then $\det[a_{i'_1}(s) \dots a_{i'_{m-p}}(s) b_{l_1}(s) \dots b_{l_p}(s)]$ has a zero at s_0 of order at least k . If all such determinants had a zero of order $> k$ and also $\det[a_1(s) \dots a_m(s)] = a(s)$ has a zero of order $\kappa > k$, then an argument like that at the start of Theorem 1 would show that $\det[A_1(s) + B_1(s)K_1, A_2(s) + B_2(s)K_2]$ would have a zero at s_0 of order $> k$ for all

imply

$$k - \kappa \leq k' - \kappa \quad \kappa = k > k'$$

which is impossible. Finally, (5.9b) and (5.9c) together are impossible. Thus we have shown that condition 2 implies condition 1. This proves the Theorem.

There is no question that the above Theorem in its general form is complicated. Therefore it is of interest to search for specializations which can take a simpler form. Section 3 described one specialization. Another is obtained by restricting to the case $\kappa=1$, i.e. s_0 is a simple pole, which implies $k=1$, i.e., the degree of s_0 as a fixed mode is 1.

Proposition 3: Assume the same hypothesis as Theorem 2, and suppose s_0 is a simple zero of $a(s)$. The following two conditions are equivalent:

1. With $[A_1(s) \ A_2(s)]^{-1} [B_1(s) \ B_2(s)]$ a left coprime matrix fraction description of $W(s)$,

$$\text{rank}[A_1(s_0) \ B_1(s_0)] < \beta \quad (5.2)$$

2. There holds

$$W(s) = \beta \begin{cases} \left. \begin{array}{l} \text{no entry has } s_0 \text{ is a simple zero} \\ \text{a pole at } s_0 \text{ of characteristic} \\ \text{polynomial of this} \\ \text{block} \end{array} \right\} \\ \text{-----} \\ \left. \begin{array}{l} \text{every entry no entry has a pole} \\ \text{has a zero at at } s_0 \\ s_0 \end{array} \right\} \end{cases} \quad (5.10)$$

It is not hard to show that this structure implies and is implied by Condition 2 of the theorem, when $k=\kappa=1$. Unfortunately, as soon as $\kappa > 1$, the situation is a good deal more complicated.

6. Conclusions

We have described a transfer function matrix test for the existence of a decentralized fixed mode; for the case when the transfer function matrix is 2×2 , or when the mode coincides with a simple pole, the test takes a particularly simple form.

We have also defined the concept of degree of a fixed mode, and illustrated the significance of this concept.

The result of this paper may be useful in elucidating whether systems of a fixed structure but with variable parameters can have a decentralized fixed mode for generic values of the parameters. Sezer and Siljak have studied this question, [9].

References

- [1] S.H. Wang and E.J. Davison, "On the Stabilization of Decentralized Control Systems," *IEEE Trans. Auto. Control*, Vol. AC-18, No. 5, 1973, pp. 473-478.
- [2] B.D.O. Anderson and D.J. Clements, "Algebraic Characterization of Fixed Modes in Decentralized Control", *Automatica*, to appear.
- [3] J.P. Corfmat and A.S. Morse, "Control of Linear Systems Through Specified Input Channels," *SIAM J. Contr. Opt.*, Vol. 14, No. 1, 1976, pp. 163-175.
- [4] J.P. Corfmat and A.S. Morse, "Decentralized Control of Linear Multivariable Systems", *Automatica*, Vol. 12, No. 5, 1976, pp.479-496.
- [5] J.M. Potter, B.D.O. Anderson and A.S. Morse, "Single Channel Control of a Two Channel System", *IEEE Trans. Auto. Control*, Vol. AC-24, No. 3, 1979, pp. 491-492.
- [6] B.D.O. Anderson and J.B. Moore, "Time-Varying Feedback Laws for Decentralized Control," *IEEE Trans. Auto. Control*, to appear.
- [7] W.A. Wolovich, "Scalar Output Feedback in Linear Multivariable Systems", *Proc. 8th Triennial World Congress, Int'l. Federation of Auto. Control, Kyoto, Japan, 1981*.
- [8] F.R. Gantmacher, *The Theory of Matrices*, Chelsea, San Francisco, 1949.
- [9] M.E. Sezer and D.D. Siljak, "Structurally Fixed Modes", Submitted for publication.

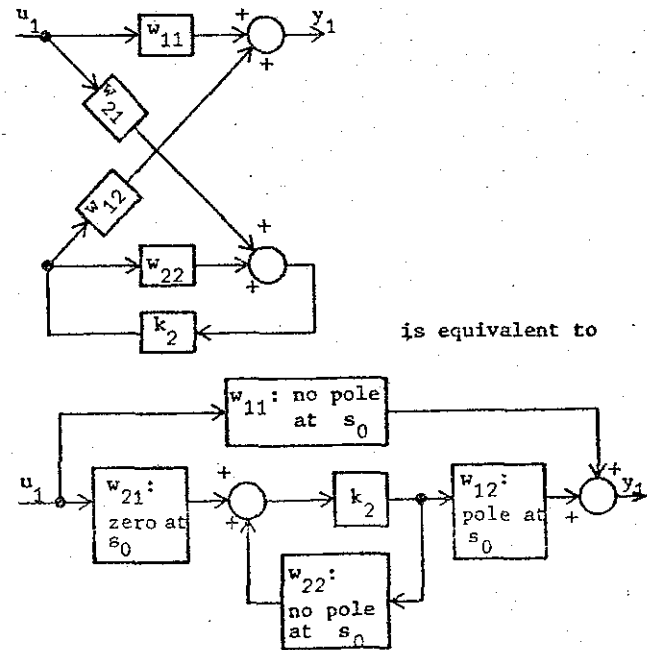

Figure 1: Illustration of fixed mode leading to uncontrollability.